



the special mosaic

ALTOGLASS



Different emotions

ALTOGLASS, S.A
Pol. Ind. Casablanca s/n
12593 MONCOFAR-Castellón
SPAIN
Tel. +34 964 577 878
Fax. +34 964 577 879
www.altoglass.com



ALTOGLASS USA
1924-28 NW 82 Avenue
MIAMI Fl. 33122 DORAL
USA
Tel. 305-718.8682
Fax. 305-718.8675
www.altoglass.com



Create new *Trends*

Original interpretation of materials, combinations of sizes and unusual harmonies of colors are proof of the creativity of emotions, pioneers of the new trends.

Interprétation originale des matériaux, des combinaisons de tailles et les harmonies de couleurs inhabituelles sont à preuve de la créativité des émotions, des pionniers des nouvelles tendances.

Original visión de los materiales, combinar diferentes tamaños y colores armoniosos son la prueba de la creatividad de las emociones, pioneros de las nuevas tendencias.

 **ALTOGLASS**





ALPHABETICAL INDEX

INDEX ALPHABÉTIQUE · ÍNDICE ALFABÉTICO

6 · 15	COOL
16 · 21	TISSUE
22 · 29	VOLCANO
30 · 43	MISCELANEA
44 · 45	MISCELANEA LUX
46 · 49	MUSEUM
50 · 53	ITALY
54 · 57	PRECIOUS STONE
58 · 61	ALPS
62	TECHNICAL DETAILS SECTION TECHNIQUE · ÁREA TÉCNICA
63	FITTING ADVISE CONSEILS DE POSE · CONSEJOS DE COLOCACIÓN
64	PACKING LIST

symbology



Matt
Mat
Mate



Shade variation
Variation de ton
Destonificación



Recommended grouts
Recommandée joint
Junta recomendada



Antislip
Antidérapant
Antideslizante



Glossy
Brillant
Brillo



Mosaic mesh
Pièce trame
Pieza enmallada



Thickness
Épaisseur
Espesor

integrated
design

The colors of the pieces may have slight differences from the original
Les couleurs des pièces peuvent présenter de légères différences par rapport aux originaux
Los colores de las piezas pueden presentar ligeras diferencias respecto a los originales

PRODUCT INDEX

INDEX DES PRODUITS · ÍNDICE DE PRODUCTO

COOL collection

6 · 15

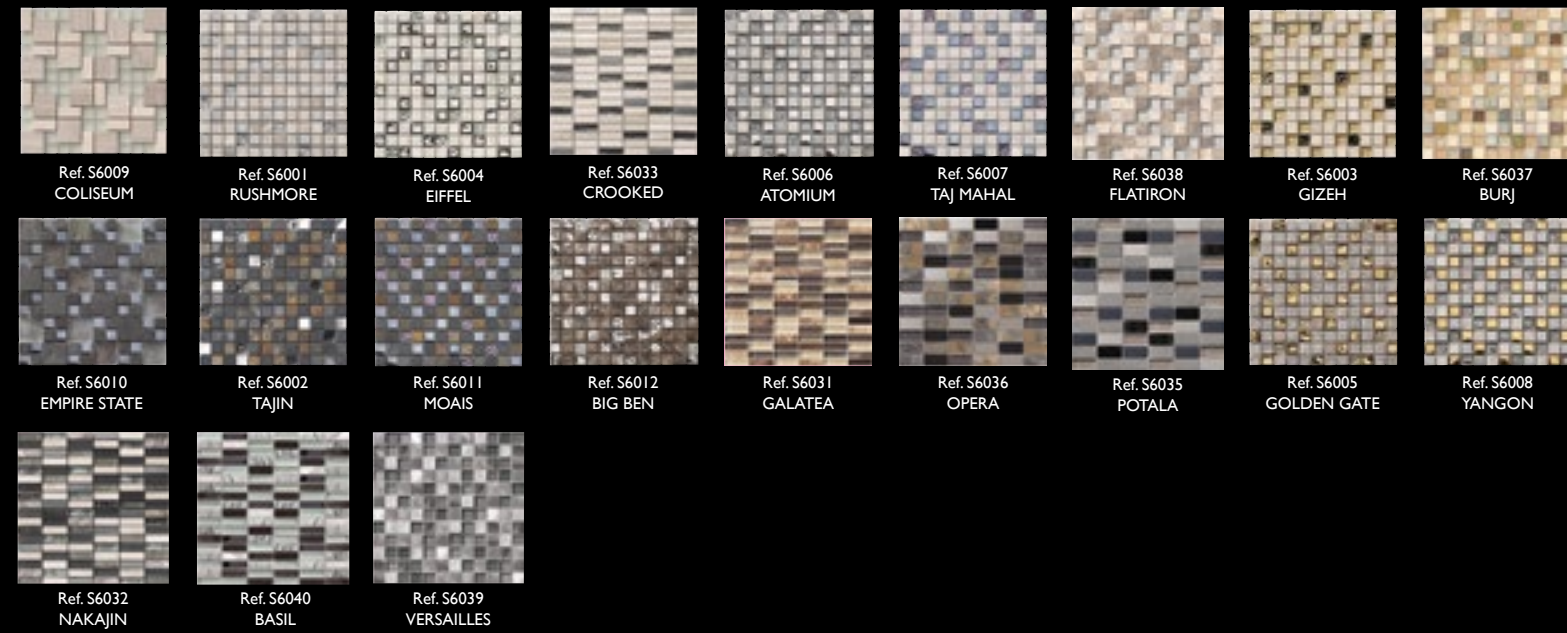

TISSUE collection

16 · 21

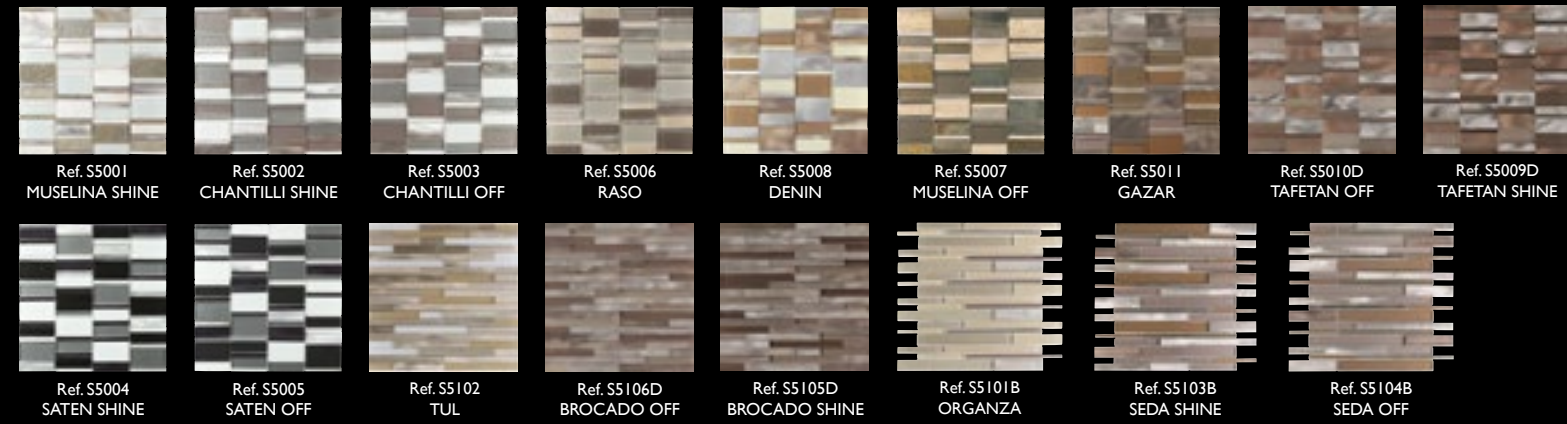

VOLCANO collection

22 · 29



MISCELANEA collection

30 · 39

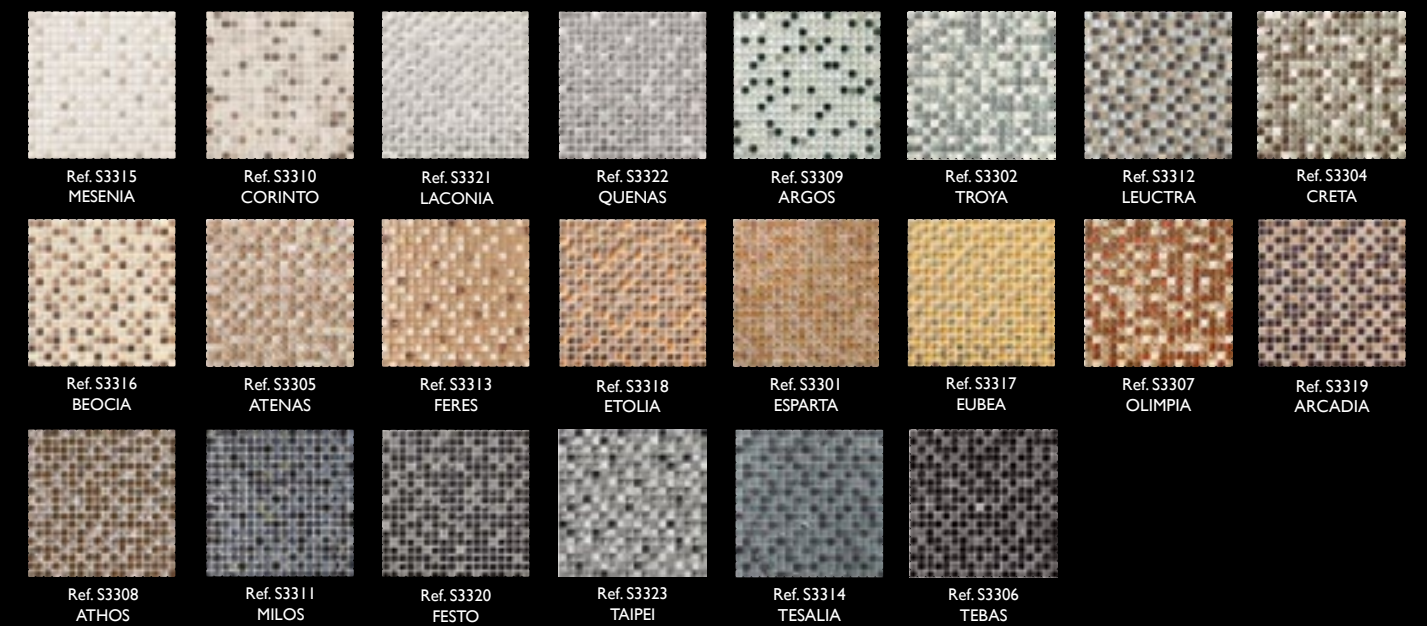

MISCELANEA LUX collection

40 · 41



MUSEUM collection

42 · 45



ITALY collection

46 · 49



PRECIOUS STONES collection

50 · 53



ALPS collection

54 · 57



COOL collection



Exclusive pieces full of texture, brilliance and colours.
A perfect combination of materials.

Des pièces exclusives, plein de texture, brillance et couleurs.
Une combinaison parfaite des matières.

Piezas exclusivas llenas de texturas, brillos y colores.
Una combinación perfecta de materiales.

BLENDS

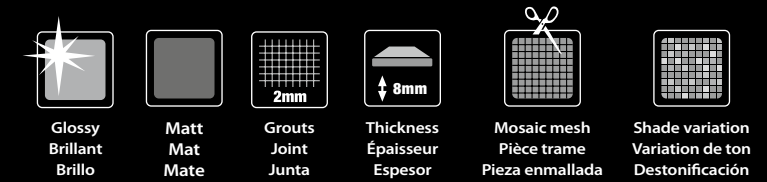

MULTIPLE FORMATS · MULTIFORMATO

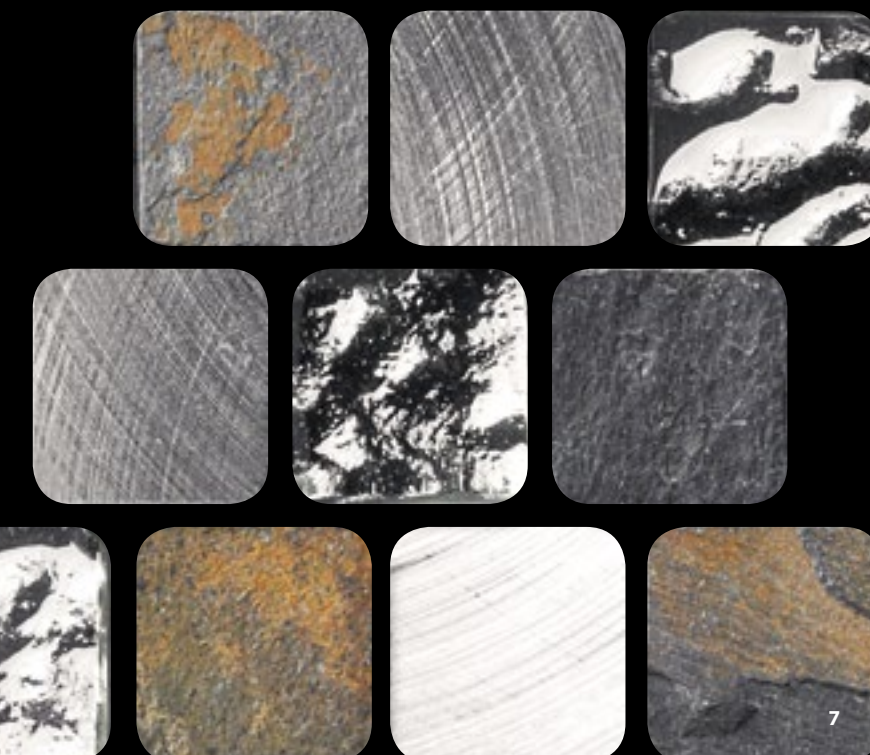
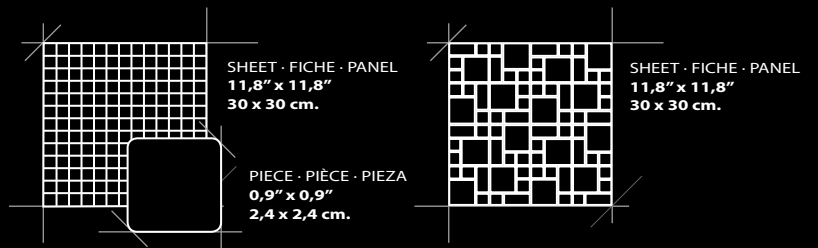
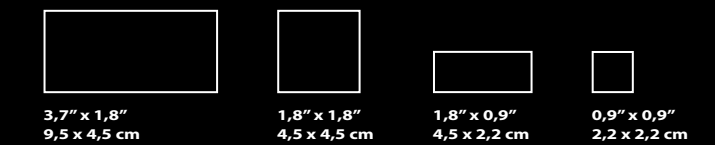



Ref. S6006 · COOL ATOMIUM · Ref. 7700 · GLAMOUR PLATA



COOL
collection

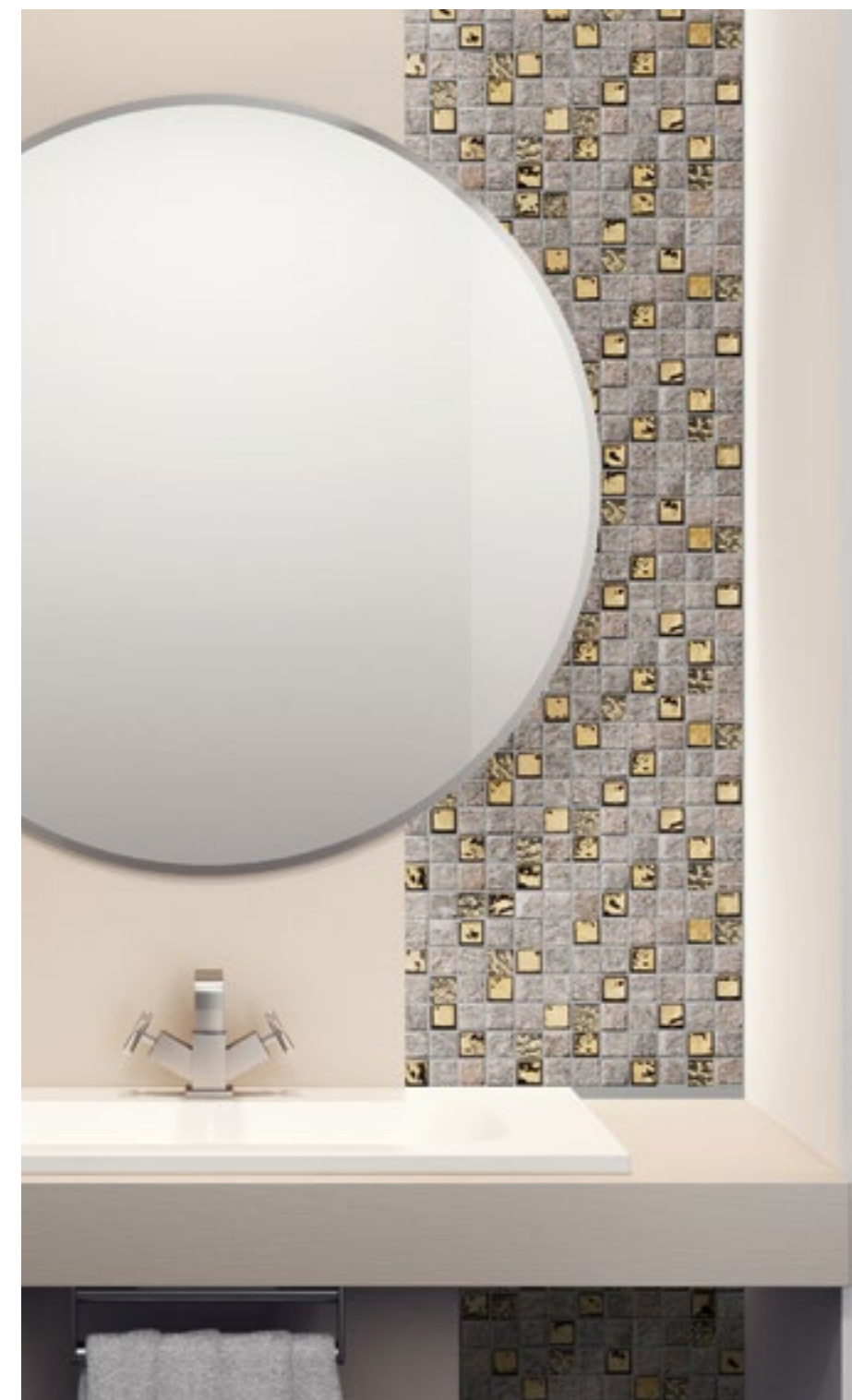

Ref. S6005 - GOLDEN GATE

COOL
collection



Ref. S6009 · COLISEUM



Ref. 6008 · YANGON



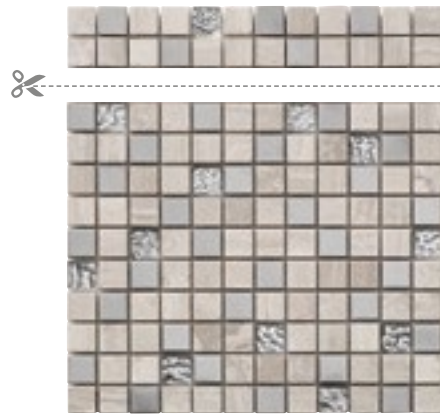

Ref. S6001 RUSHMORE | A-37

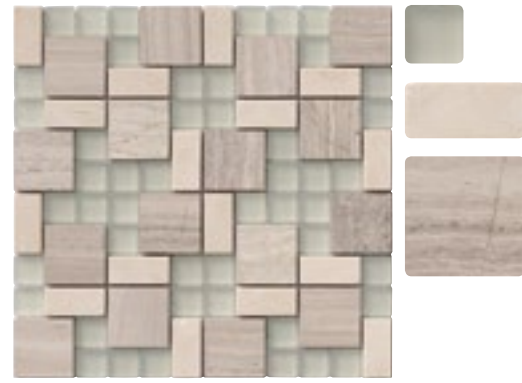

Ref. S6009 COLISEUM | A-37

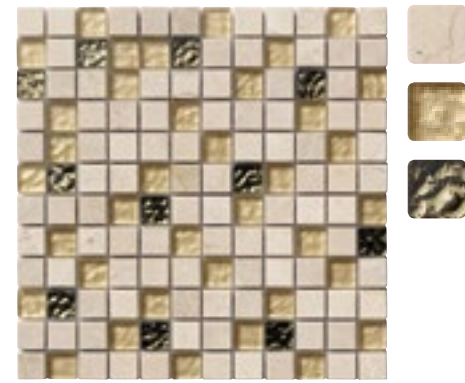

Ref. S6003 GIZEH | A-37

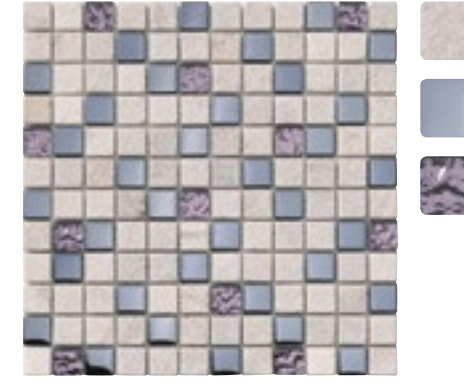

Ref. S6007 TAJ MAHAL | A-37

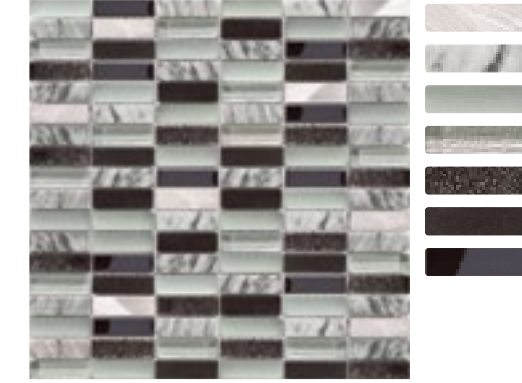

Ref. S6040 BASIL | A-36

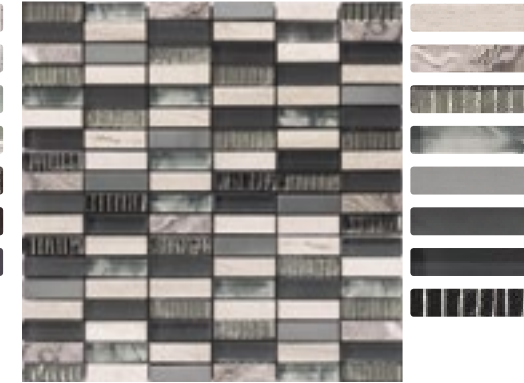

Ref. S6032 NAKAGIN | A-39



Ref. S6004 EIFFEL | A-37



Ref. S6038 FLATIRON | A-36

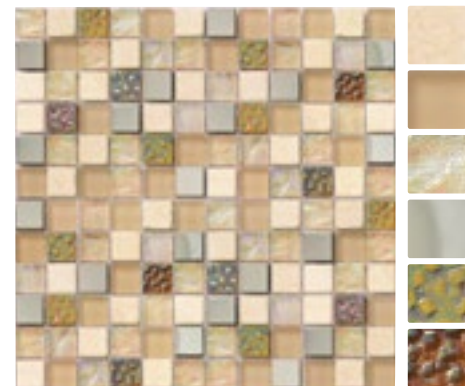

Ref. S6037 BURJ | A-36

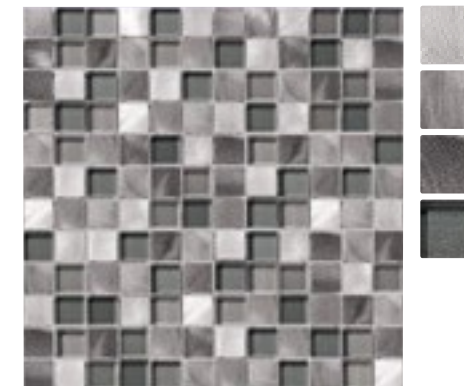

Ref. S6039 VERSAILLES | A-36

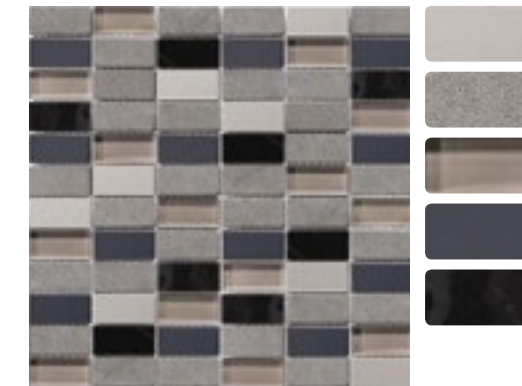

Ref. S6035 POTALA | A-36

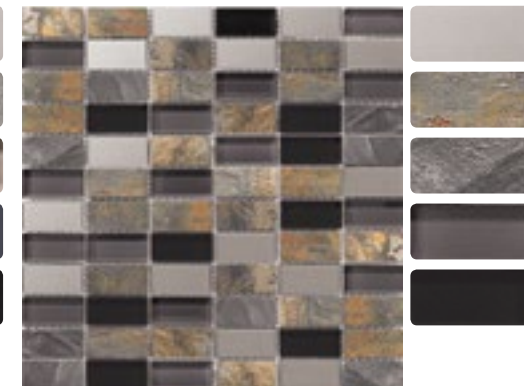

Ref. S6036 OPERA | A-36

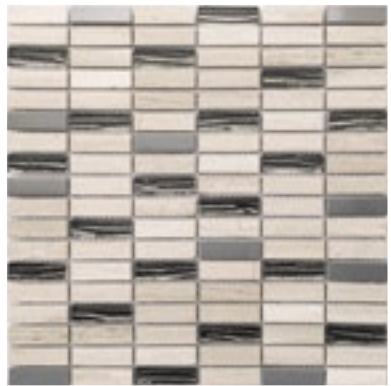

Ref. S6033 CROOKED | A-36

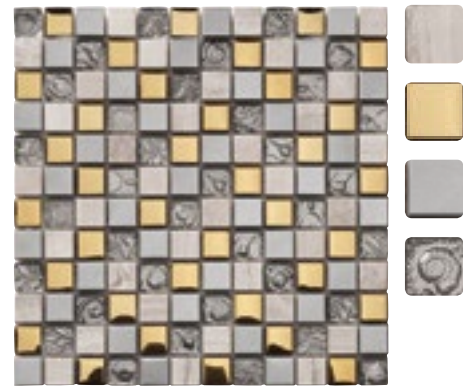

Ref. S6008 YANGON | A-37

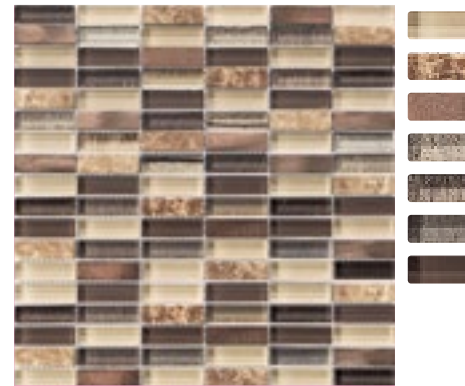

Ref. S6031 GALATEA | A-36

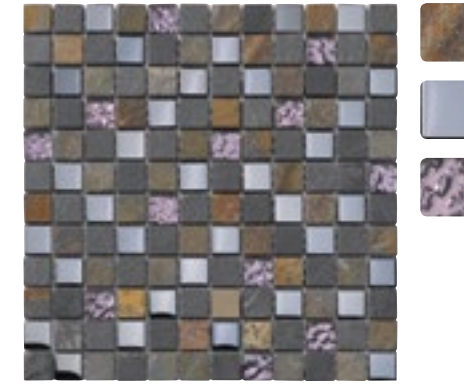

Ref. S6011 MOAIS | A-37

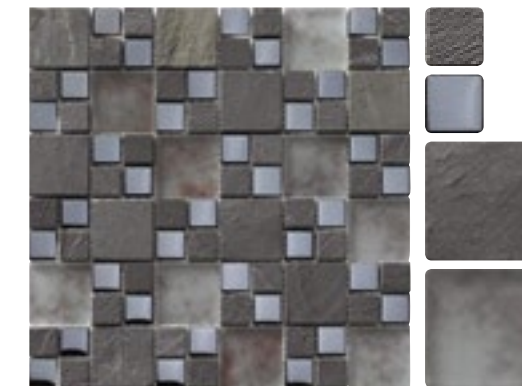

Ref. S6010 EMPIRE STATE | A-37

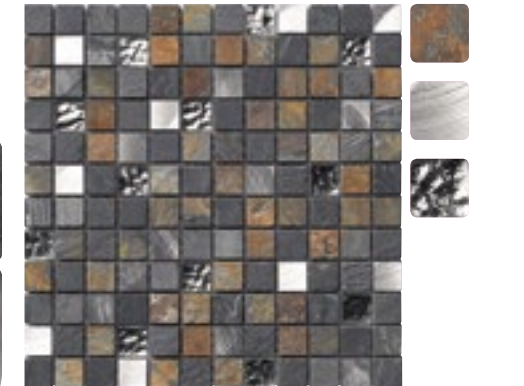

Ref. S6002 TAJIN | A-37



Ref. S6006 ATOMIUM | A-37

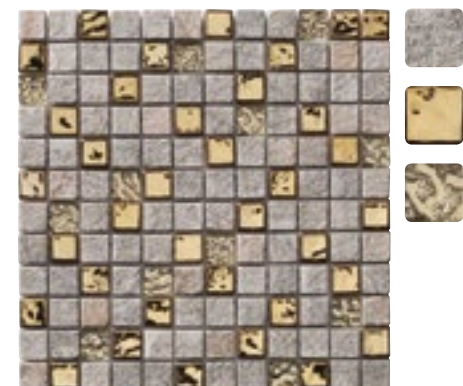

Ref. S6005 GOLDEN GATE | A-37

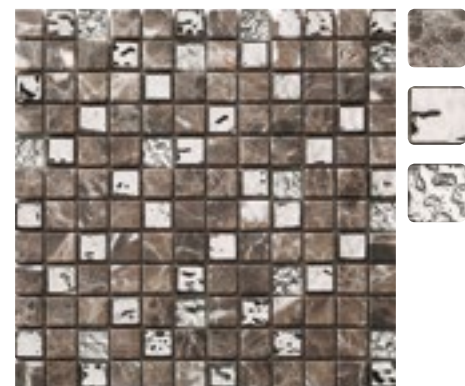

Ref. S6012 BIG BEN | A-37

PACKING COOL

SIZE / MESH DIMENSIÓN / HOJA	WEIGHT / BOX PESO / CAJA	M ² / BOX M ² / CAJA	PIECES / BOX PIEZAS / CAJA	BOXES / PALLET · EUROPAL. CAJAS / PALET · EUROPAL.	M ² / PALLET · EUROPAL. M ² / PALET · EUROPAL.	WEIGHT / PALLET · EUROPAL. PESO / PALET · EUROPAL.
30 x 30 cm. · 11,7" x 11,7"	16 kg	1 m ²	11	72 cajas · 42 cajas	72 m ² · 42 m ²	1.152 kg · 672 kg

SIZE / PALLET · MEDIDAS / PALET 105 x 105 x 90 cm.

SIZE / EUROPALET · MEDIDAS / EUROPALET 120 x 80 x 90 cm.



TISSUE *collection*









Natural and harmonious colours. Shine and matt mixed in a net of pieces with great esthetic wealth. Multisizes that adapt to any design.

Des couleurs naturelles et harmonieuses. Brillant et mat se mélangent dans un réseau des pièces qui apportent une richesse d'esthétique. Des multiformats qui s'adaptent aux dessins différentes.

Colores naturales y armoniosos. Brillos y mates que se entremezclan en una red de piezas de gran riqueza estética. Múltiples formatos que se adaptan a cualquier diseño.

BLENDS

					
Glossy Brillant Brillo	Matt Mat Mate	Grouts Joint Junta	Thickness Épaisseur Espesor	Mosaic mesh Pièce trame Pieza enmallada	Shade variation Variation de ton Destonificación

MULTIPLE FORMATS · MULTIFORMATO

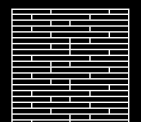
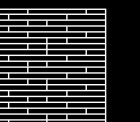
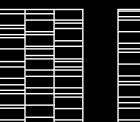
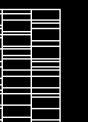
				
12,3" x 13,3" 31,2 x 33,8 cm	11,4" x 11,8" 29 x 30 cm	11,8" x 11,8" 30 x 30 cm	11,4" x 11,8" 29 x 30 cm	12,7" x 11,8" 32,4 x 30 cm

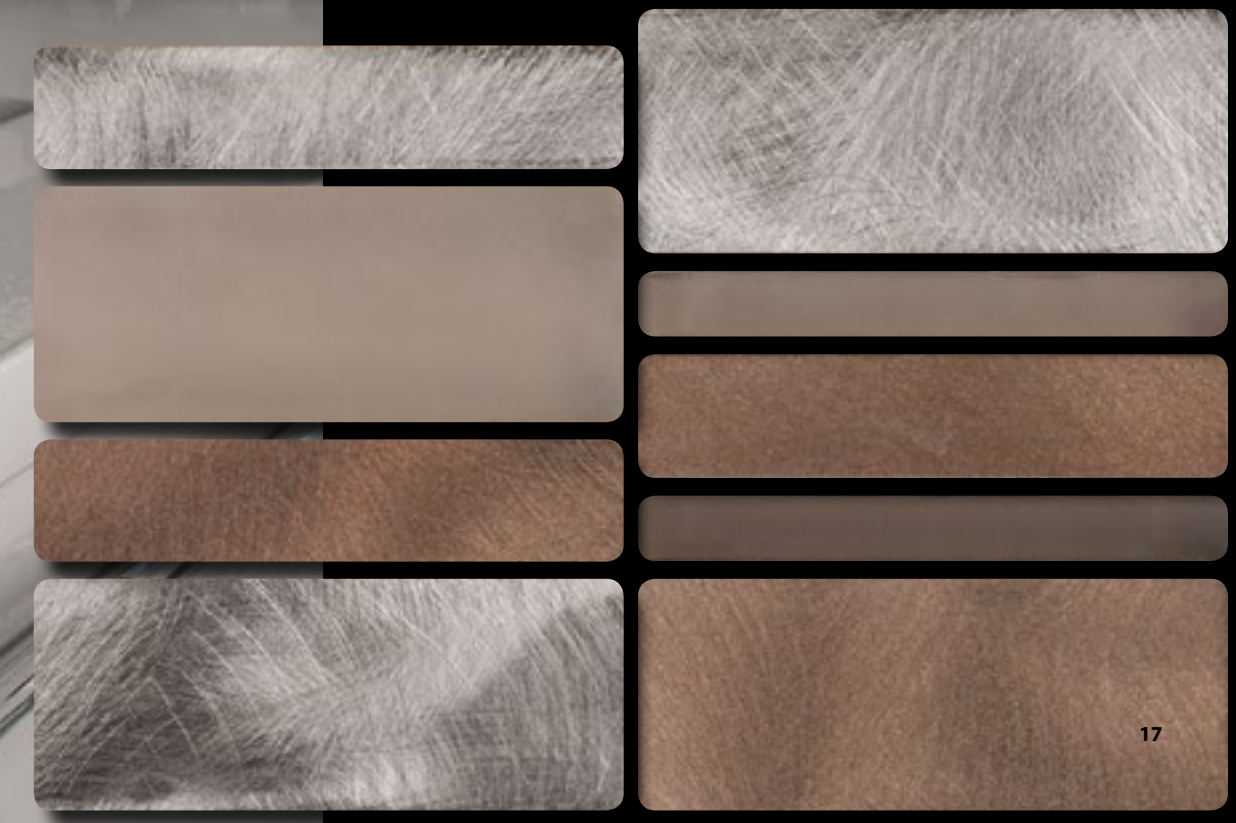

TISSUE
collection

create new trends
crear nuevas tendencias



Ref. S5106D · TISSUE BROCADO OFF · Ref. ME0001 · MUSEUM LOUVRE



Ref. S5003 · TISSUE CHANTILLI OFF

TISSUE

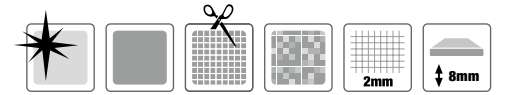

Blends · Composiciones · Combinados

MULTIPLE FORMATS · MULTIFORMATO

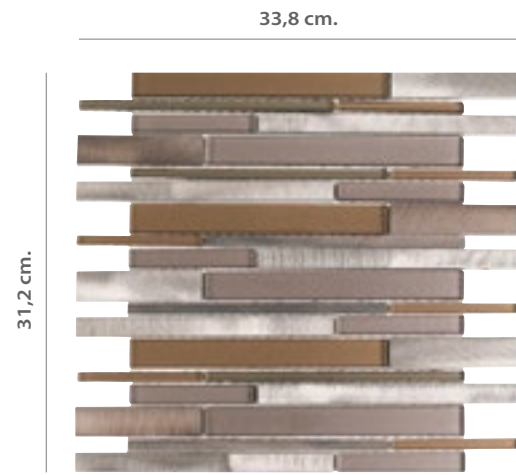

Ref. S5103B SEDA SHINE | A-42

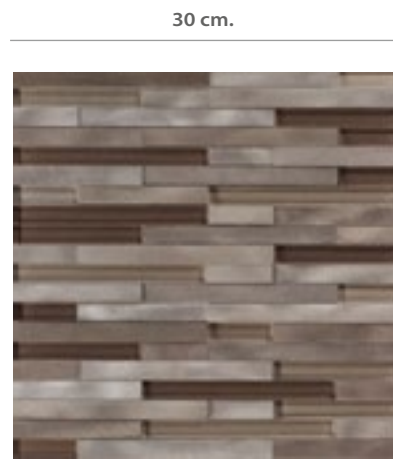

Ref. S5105D BROCADO SHINE | A-43

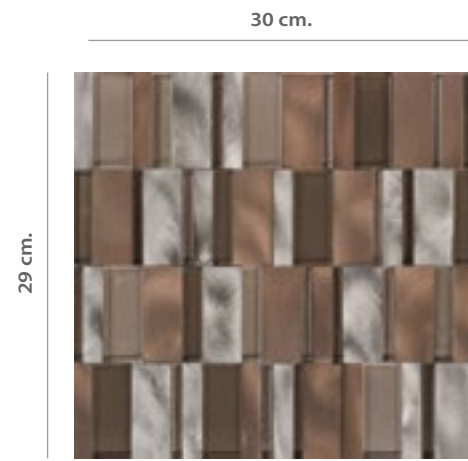

Ref. S5009D TAFETAN SHINE | A-43

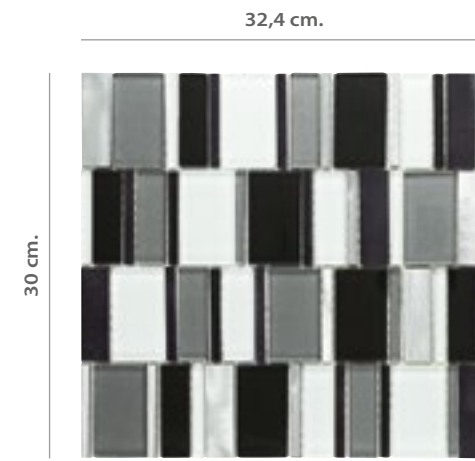

Ref. S5004 SATEN SHINE | A-41



Ref. S5002 CHANTILLI SHINE | A-41



Ref. S5001 MUSELINA SHINE | A-41

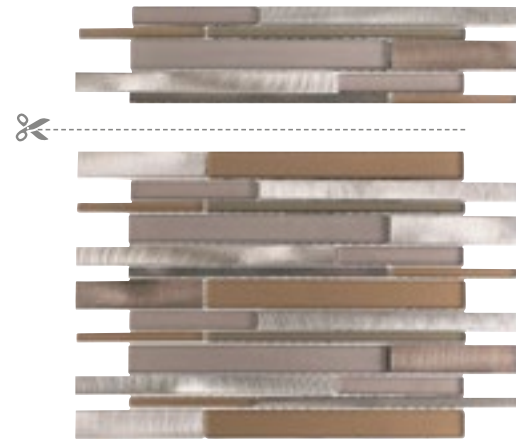

Ref. S5104B SEDA OFF | A-42



Ref. S5106D BROCADO OFF | A-43

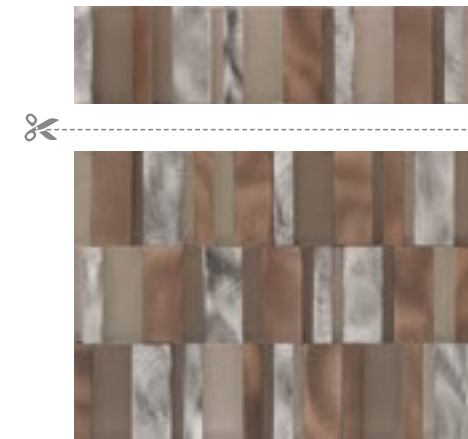

Ref. S5010D TAFETAN OFF | A-43

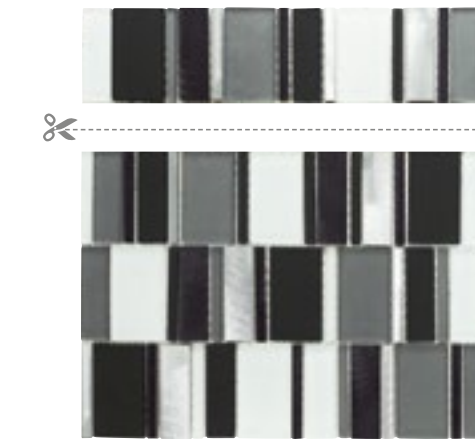

Ref. S5005 SATEN OFF | A-41



Ref. S5003 CHANTILLI OFF | A-41



Ref. S5007 MUSELINA OFF | A-41



Ref. S5101B ORGANZA | A-42

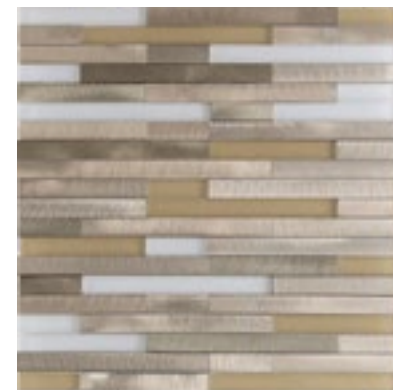

Ref. S5102 TUL | A-42



Ref. S5006 RASO | A-41



Ref. S5008 DENIN | A-41

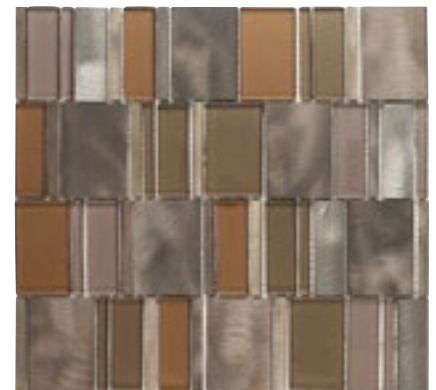

Ref. S5011 GAZAR | A-41

PACKING TISSUE

SIZE / MESH DIMENSIÓN / HOJA	WEIGHT / BOX PESO / CAJA	M ² / BOX M ² / CAJA	PIECES / BOX PIEZAS / CAJA	BOXES / PALLET · EUROPAL. CAJAS / PALET · EUROPAL.	M ² / PALLET · EUROPAL. M ² / PALET · EUROPAL.	WEIGHT / PALLET · EUROPAL. PESO / PALET · EUROPAL.
31,2 x 33,8 cm. · 12,3" x 13,3"	11,76 kg	1,16 m ²	11	72 cajas · 42 cajas	83,44 m ² · 48,67 m ²	847,06 kg · 494,12 kg
SEDA OFF 31,2 x 33,8 cm. · 12,3" x 13,3"	12,79 kg	1,16 m ²	11	72 cajas · 42 cajas	83,44 m ² · 48,67 m ²	921,18 kg · 537,35 kg
32,4 x 30 cm. · 12,7" x 11,8"	11,76 kg	1,07 m ²	11	72 cajas · 42 cajas	77,08 m ² · 44,96 m ²	847,06 kg · 494,12 kg

SIZE / PALLET · MEDIDAS / PALET 105 x 105 x 90 cm.

SIZE / EUROPALLET · MEDIDAS / EUROPALET 120 x 80 x 90 cm.

PACKING TISSUE

SIZE / MESH DIMENSIÓN / HOJA	WEIGHT / BOX PESO / CAJA	M ² / BOX M ² / CAJA	PIECES / BOX PIEZAS / CAJA	BOXES / PALLET · EUROPAL. CAJAS / PALET · EUROPAL.	M ² / PALLET · EUROPAL. M ² / PALET · EUROPAL.	WEIGHT / PALLET · EUROPAL. PESO / PALET · EUROPAL.
TUL 30 x 30 cm. · 11,8" x 11,8"	7 kg	0,99 m ²	11	72 cajas · 42 cajas	71,20 m ² · 41,53 m ²	504 kg · 294 kg
30 x 30 cm. · 11,8" x 11,8"	6,98 kg	0,63 m ²	7	72 cajas · 42 cajas	45,37 m ² · 26,47 m ²	502,86 kg · 293,33 kg
29 x 30 cm. · 11,4" x 11,8"	6,98 kg	0,61 m ²	7	72 cajas · 42 cajas	43,89 m ² · 25,60 m ²	502,86 kg · 293,33 kg

SIZE / PALLET · MEDIDAS / PALET 105 x 105 x 90 cm.

SIZE / EUROPALLET · MEDIDAS / EUROPALET 120 x 80 x 90 cm.



VOLCANO *collection*



Get unique places, plenty of refined shines. A full sea of small intertwined pearls. An authentic jewel.

Obtient d'uniqes espaces, repus de précieuses brillances. Une mer de petites perles enlacées. Un véritable joyau.

Consigue espacios únicos, repletos de exquisitos brillos. Todo un mar de pequeñas perlas entrelazadas. Una auténtica joya.

SOLID COLORS + BLENDS



Glossy
Brillant
Brillo

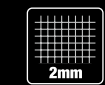

Grouts
Joint
Junta



Thickness
Épaisseur
Espesor



Mosaic mesh
Pièce trame
Pieza enmallada

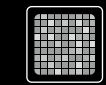

Shade variation
Variation de ton
Destonificación

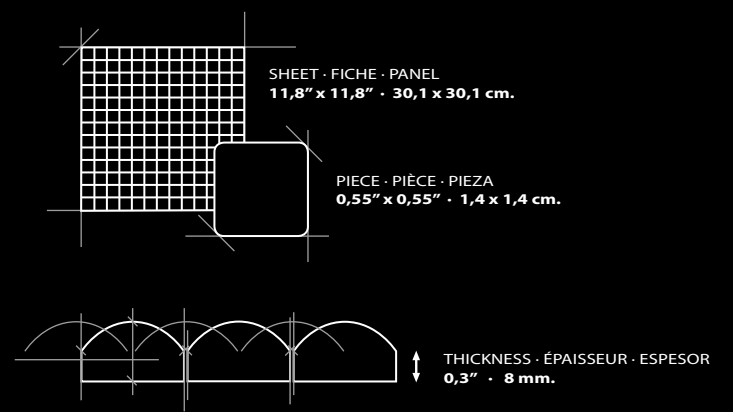

VOLCANO *collection*



Ref. J0006 · VOLCANO MAYON
24 Ref. J1002 · BLEND SANTORINI / COMBINADO SANTORINI

VOLCANO

Solid colors · Lisses · Lisos

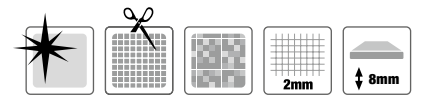

Piece 0,55" x 0,55" · Pieza 1,4 x 1,4 cm. Sheet 11,8" x 11,8" · Panel 30,1 x 30,1 cm.

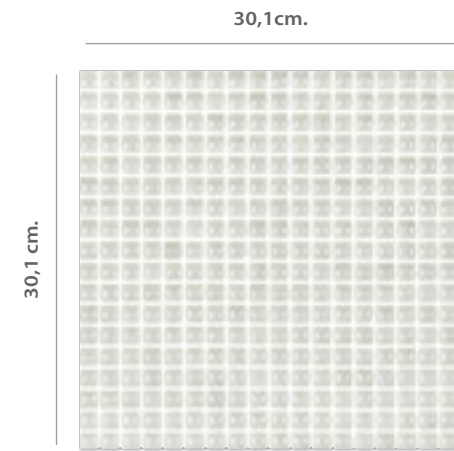

Ref. J0001 ANVIL | A-33

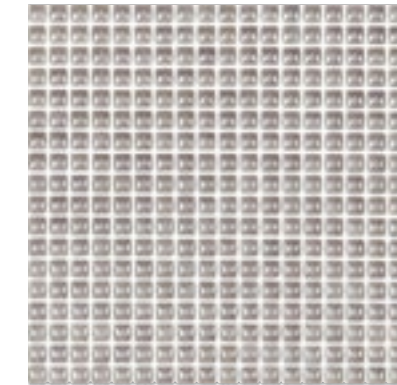

Ref. J0002 RAINER | A-33

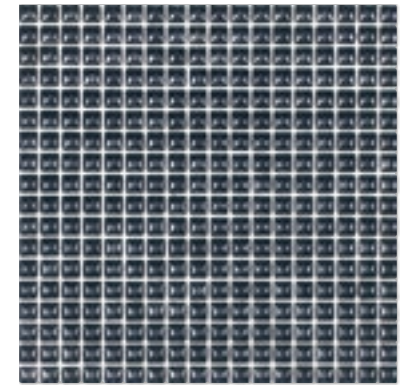

Ref. J0004 ULAWUN | A-33

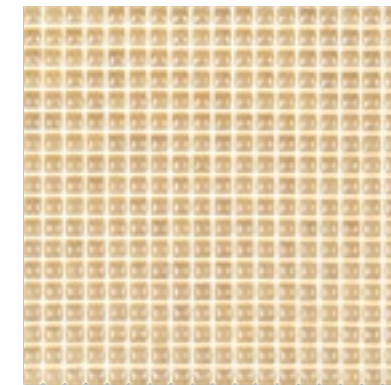

Ref. J0003 JALISCO | A-33

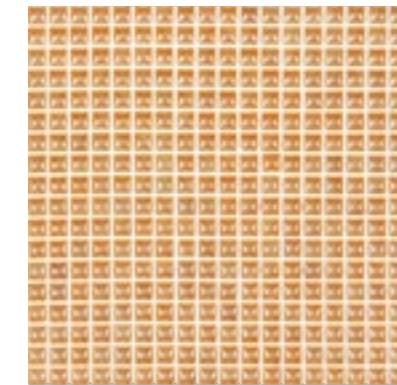

Ref. J0005 MERAPI | A-33

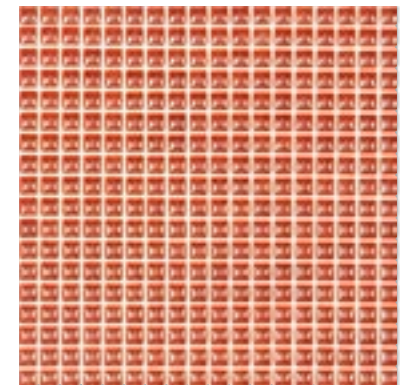

Ref. J0006 MAYON | A-33



Ref. J0004 · VOLCANO ULAWUN

VOLCANO

collection

an authentic jewel

una auténtica joya



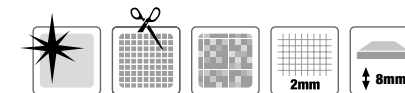

Blends · Composiciones · Combinados

Piece 0,55" x 0,55" · Pieza 1,4 x 1,4 cm.
Sheet 11,8" x 11,8" · Panel 30,1 x 30,1 cm.



Ref. J1001 · BLEND UNZEN / COMBINADO UNZEN



28 Ref. J1004 · BLEND ETNA / COMBINADO ETNA

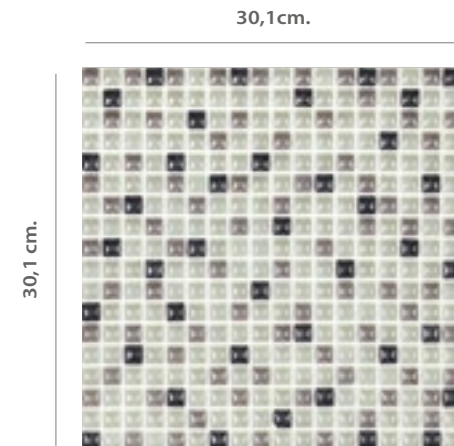

Ref. J1001 UNZEN | A-34
J0001 (33%) + J0002 (33%) + J0004 (33%)

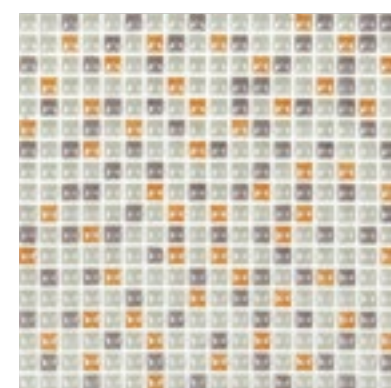

Ref. J1006 TEIDE | A-34
J0001 (33%) + J0002 (33%) + J0005 (33%)

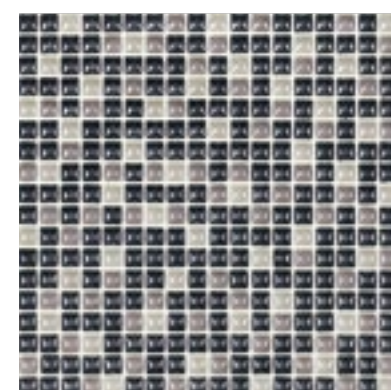

Ref. J1005 TAAL | A-34
J0001 (33%) + J0002 (33%) + J0004 (33%)

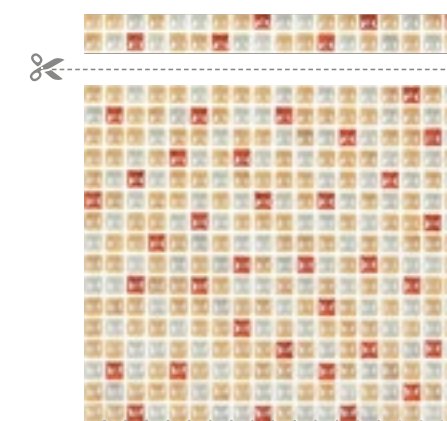

Ref. J1002 SANTORINI | A-34
J0001 (33%) + J0003 (33%) + J0006 (33%)

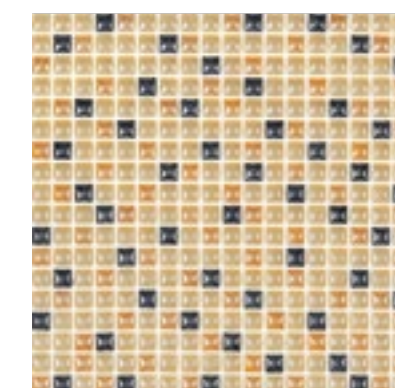

Ref. J1003 COLIMA | A-34
J0003 (33%) + J0005 (33%) + J0004 (33%)

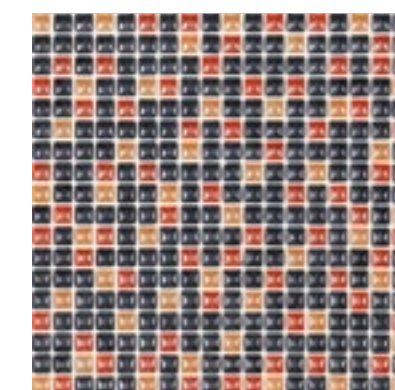

Ref. J1004 ETNA | A-34
J0005 (33%) + J0006 (33%) + J0004 (33%)

PACKING VOLCANO

SIZE / MESH DIMENSIÓN / HOJA	WEIGHT / BOX PESO / CAJA	M ² / BOX M ² / CAJA	PIECES / BOX PIEZAS / CAJA	BOXES / PALLET · EUROPALLET CAJAS / PALET · EUROPALET	M ² / PALLET · EUROPALLET M ² / PALET · EUROPALET	WEIGHT / PALLET · EUROPALLET PESO / PALET · EUROPALET
30,1 x 30,1 x 0,8 cm. 11,7" x 11,7" x 0,3	14 kg	1 m ²	11	63 cajas · 42 cajas	63 m ² · 42 m ²	882 kg · 588 kg

SIZE / PALLET · MEDIDAS / PALET 105 x 105 x 90 cm.

SIZE / EUROPALLET · MEDIDAS / EUROPALET 120 x 80 x 108 cm.



MISCELANEA *collection*



Ancient Greece is the source of inspiration for new mosaics, with exquisite combinations of fine marble and exotic coloured glass.

Influences de l'ancienne Grèce inspirent de nouvelles mosaïques, exquisites combinaisons entre marbres nobles et d'exotiques verres colorés.

Influencias de la antigua Grecia inspiran nuevos mosaicos, exquisitas combinaciones entre nobles mármoles y exóticos vidrios coloreados.

BLENDS

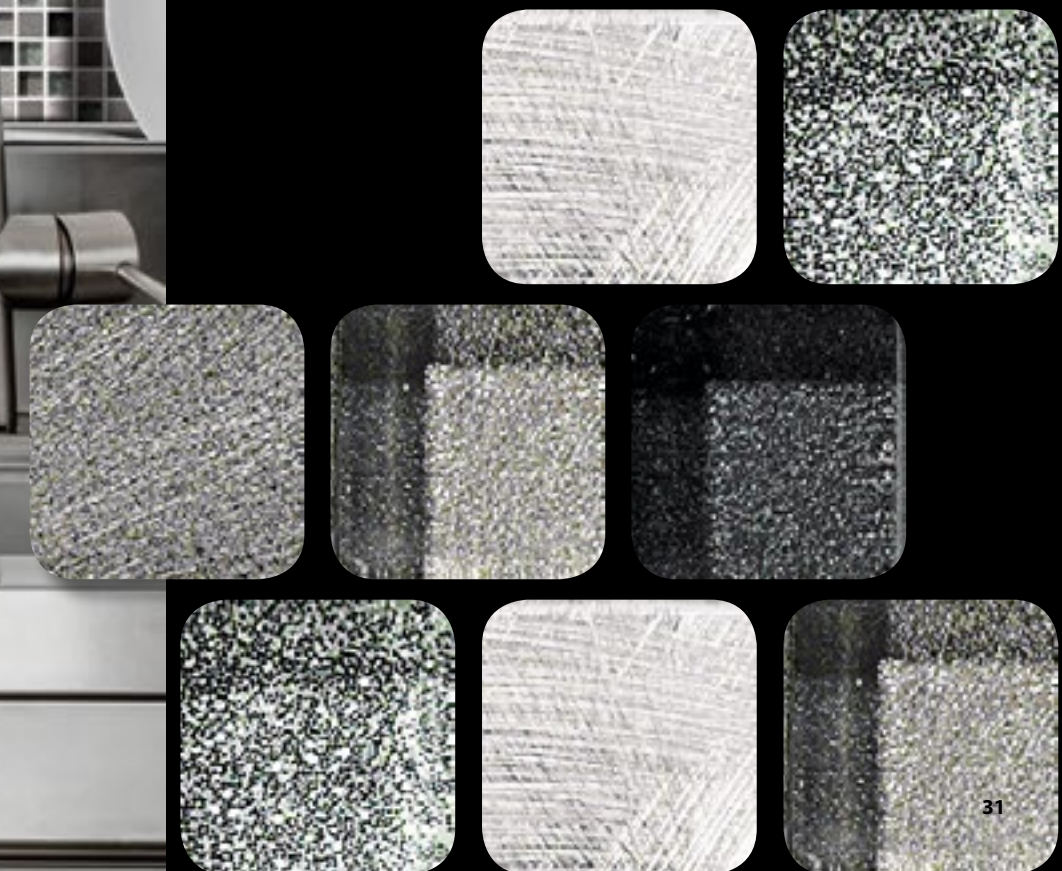
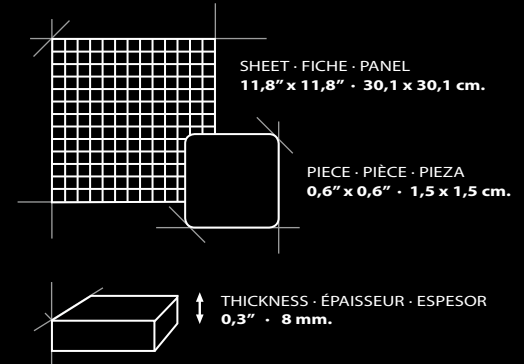
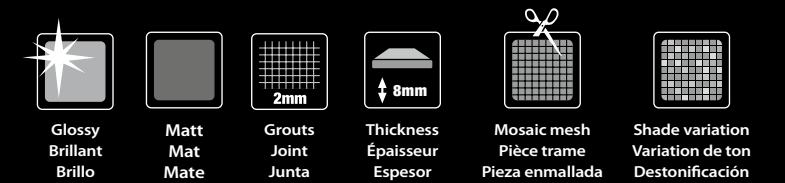

MISCELANEA *collection*



Ref. S3303 · TEBAS



Ref. S3321 · LACONIA



Ref. S3309 · ARGOS



Ref. S3320 · FESTO



Ref. S3322 · QUENAS



Ref. S3320 · FESTO



Ref. S3321 · LACONIA 35

MISCELANEA
collection

melting pot of styles
and materials
mezcla de estilos y materiales



36 Ref. S3310 · BLEND CORINTO / COMBINADO CORINTO



Ref. S3307 · BLEND OLIMPIA / COMBINADO OLIMPIA

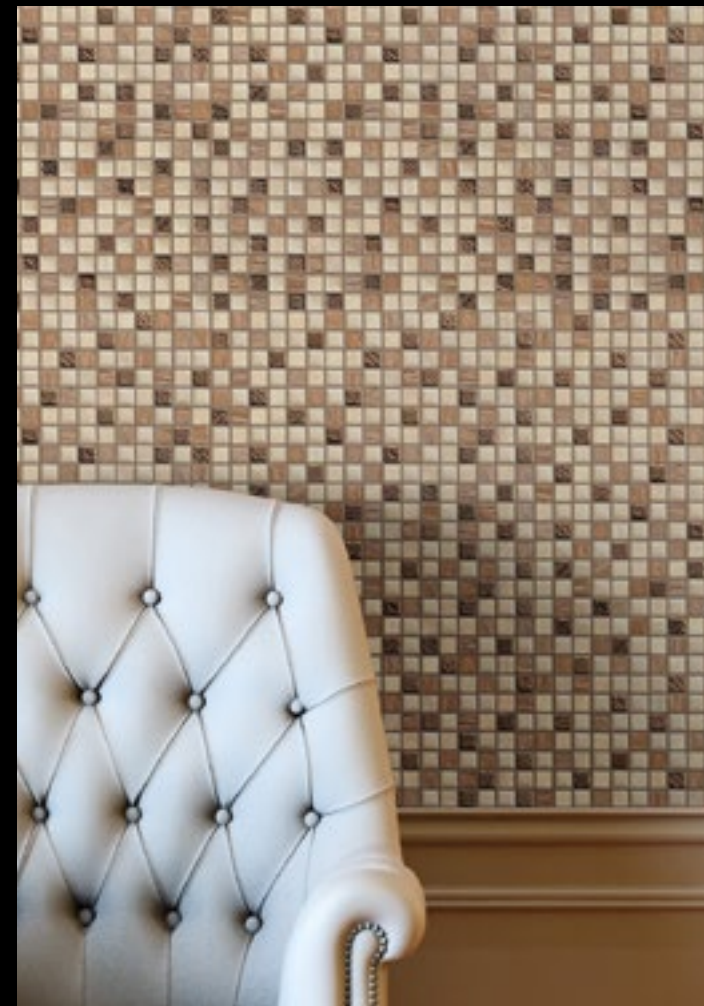

Ref. S3316 · BEOCIA



Ref. S3318 · ETOLIA

MISCELANEA
collection

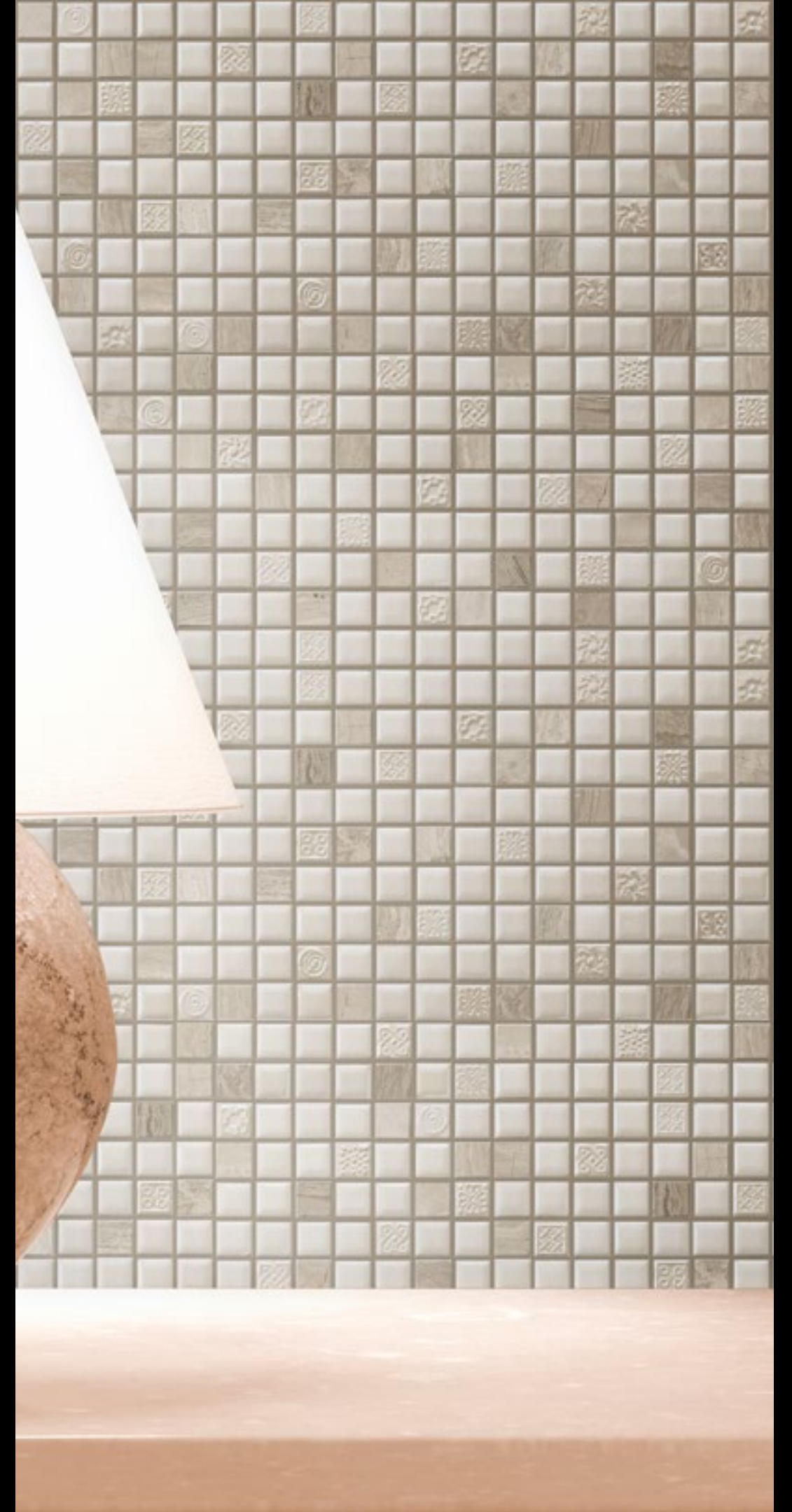



Ref. S3314 · TESALIA



Ref. S3301 · ESPARTA



Ref. S3308 · ATHOS

MISCELANEA

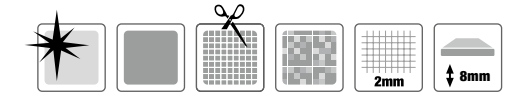

Blends · Composiciones · Combinados

Piece 0,6" x 0,6" · Pieza 1,5 x 1,5 cm.
Sheet 11,8" x 11,8" x 0,3" · Panel 30,1 x 30,1 x 0,8 cm.

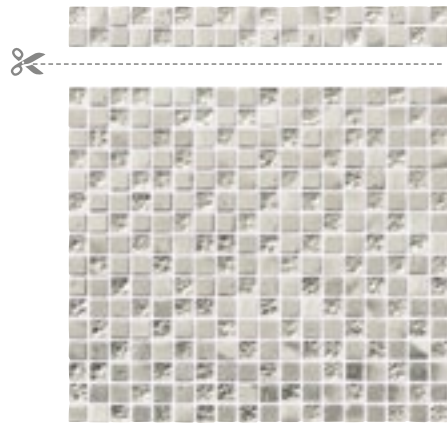

Ref. S3321 LACONIA | A-35

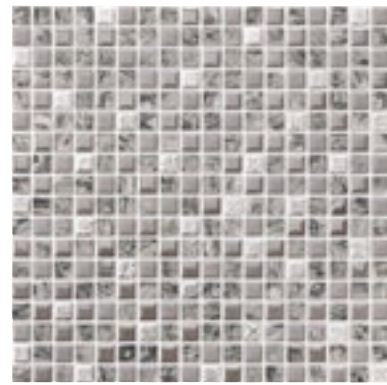

Ref. S3322 QUENAS | A-35

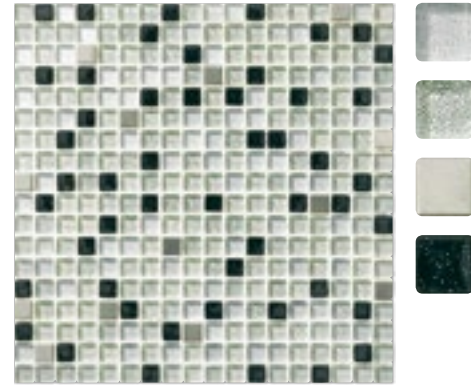

Ref. S3309 ARGOS | A-35

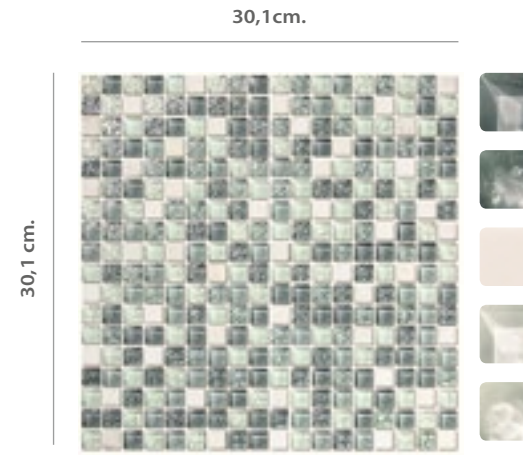

Ref. S3302 TROYA | A-34

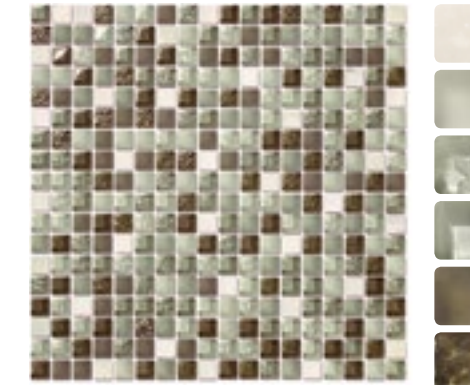

Ref. S3304 CRETA | A-34

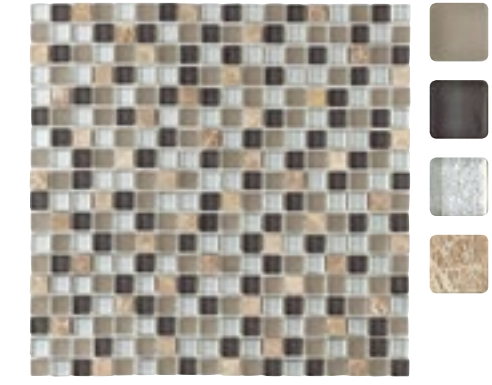

Ref. S3312 LEUCTRA | A-34

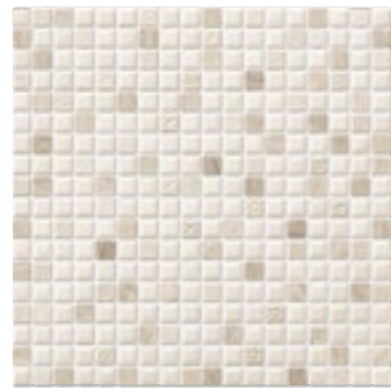

Ref. S3315 MESENA | A-35



Ref. S3310 CORINTO | A-35

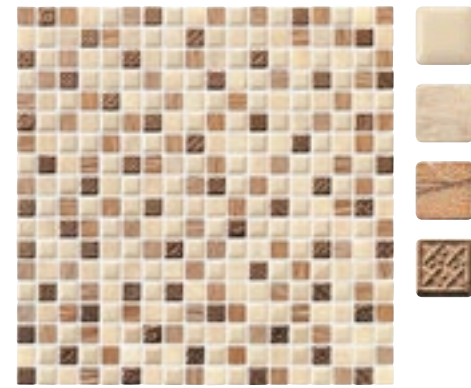

Ref. S3316 BEOCIA | A-35

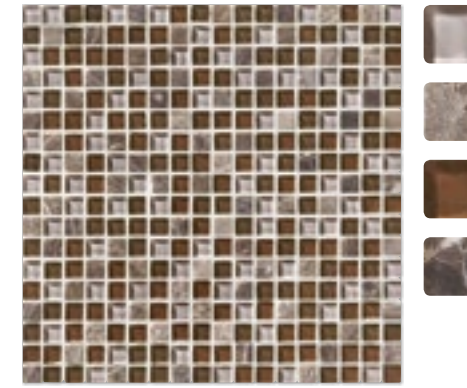

Ref. S3308 ATHOS | A-34

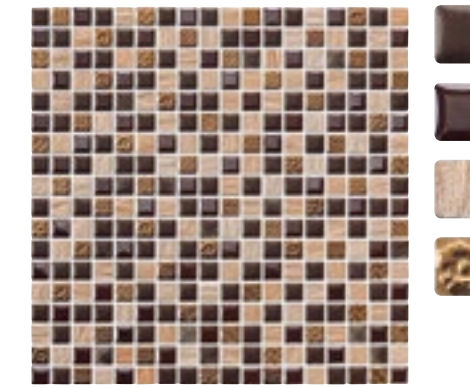

Ref. S3319 ARCADIA | A-35

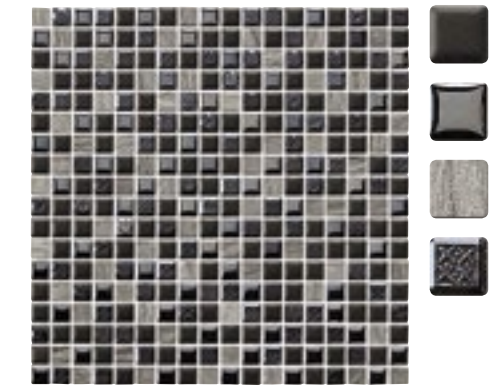

Ref. S3320 FESTO | A-35

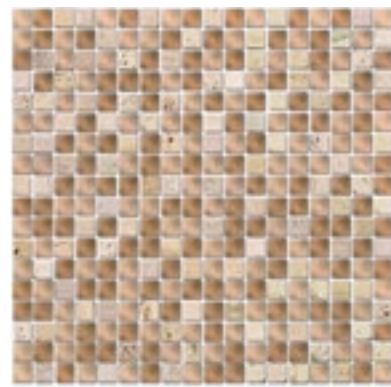

Ref. S3305 ATENAS | A-34



Ref. S3313 FERES | A-34

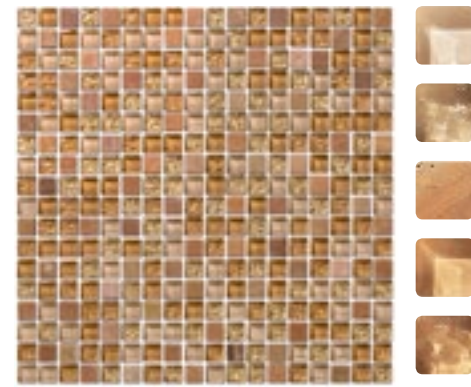

Ref. S3301 ESPARTA | A-34

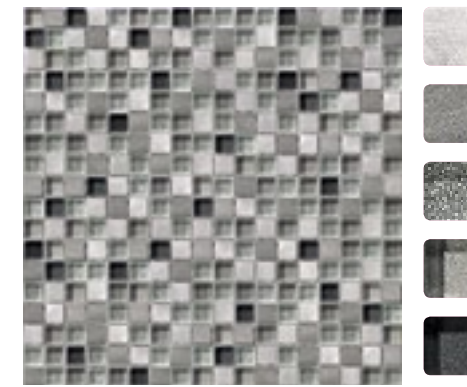

Ref. S3323 TAIPEI | A-39

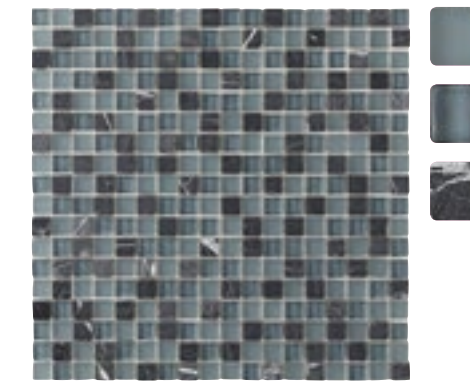

Ref. S3314 TESALIA | A-34

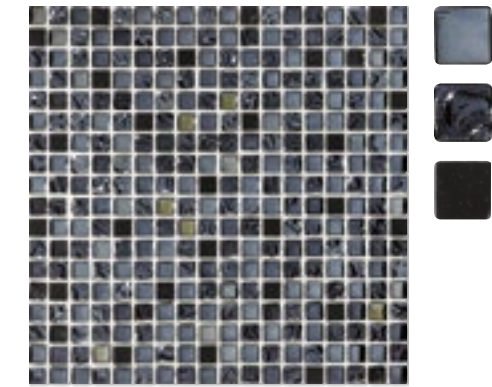

Ref. S3311 MILOS | A-35

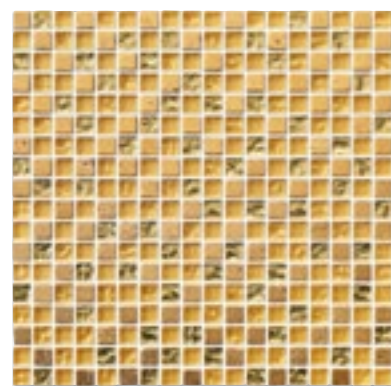

Ref. S3317 EUBEA | A-35

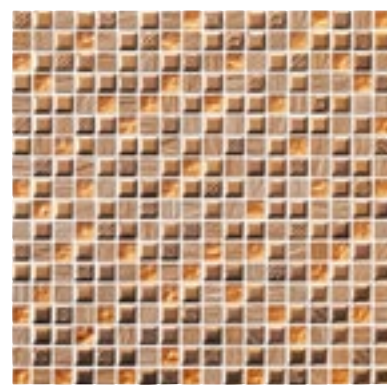

Ref. S3318 ETOLIA | A-35

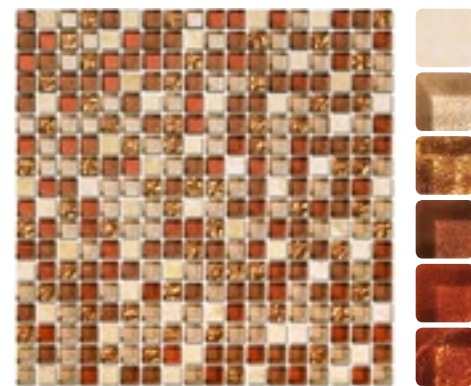

Ref. S3307 OLIMPIA | A-34

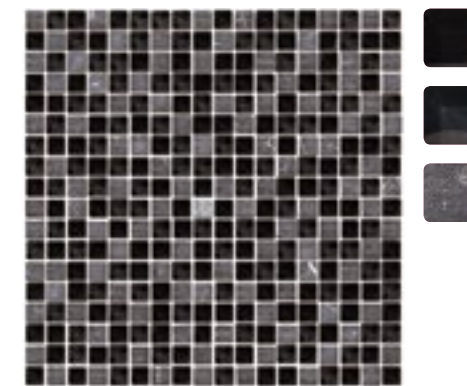

Ref. S3306 TEBAS | A-34

PACKING MISCELANEA

SIZE / MESH DIMENSIÓN / HOJA	WEIGHT / BOX PESO / CAJA	M ² / BOX M ² / CAJA	PIECES / BOX PIEZAS / CAJA
30,1 x 30,1 x 0,8 cm. 11,7" x 11,7" x 0,3"	15,30 kg	1 m ²	11

BOXES / PALLET · EUROPALLET CAJAS / PALET · EUROPALET	M ² / PALLET · EUROPALLET M ² / PALET · EUROPALET	WEIGHT / PALLET · EUROPALLET PESO / PALET · EUROPALET
63 cajas · 42 cajas	63 m ² · 42 m ²	964 kg · 642,30 kg

SIZE / PALLET · MEDIDAS / PALET 105 x 105 x 90 cm.

SIZE / EUROPALLET · MEDIDAS / EUROPALET 120 x 80 x 108 cm.

MISCELANEA LUX

collection



Ref. S3375 · ROMAN RECT

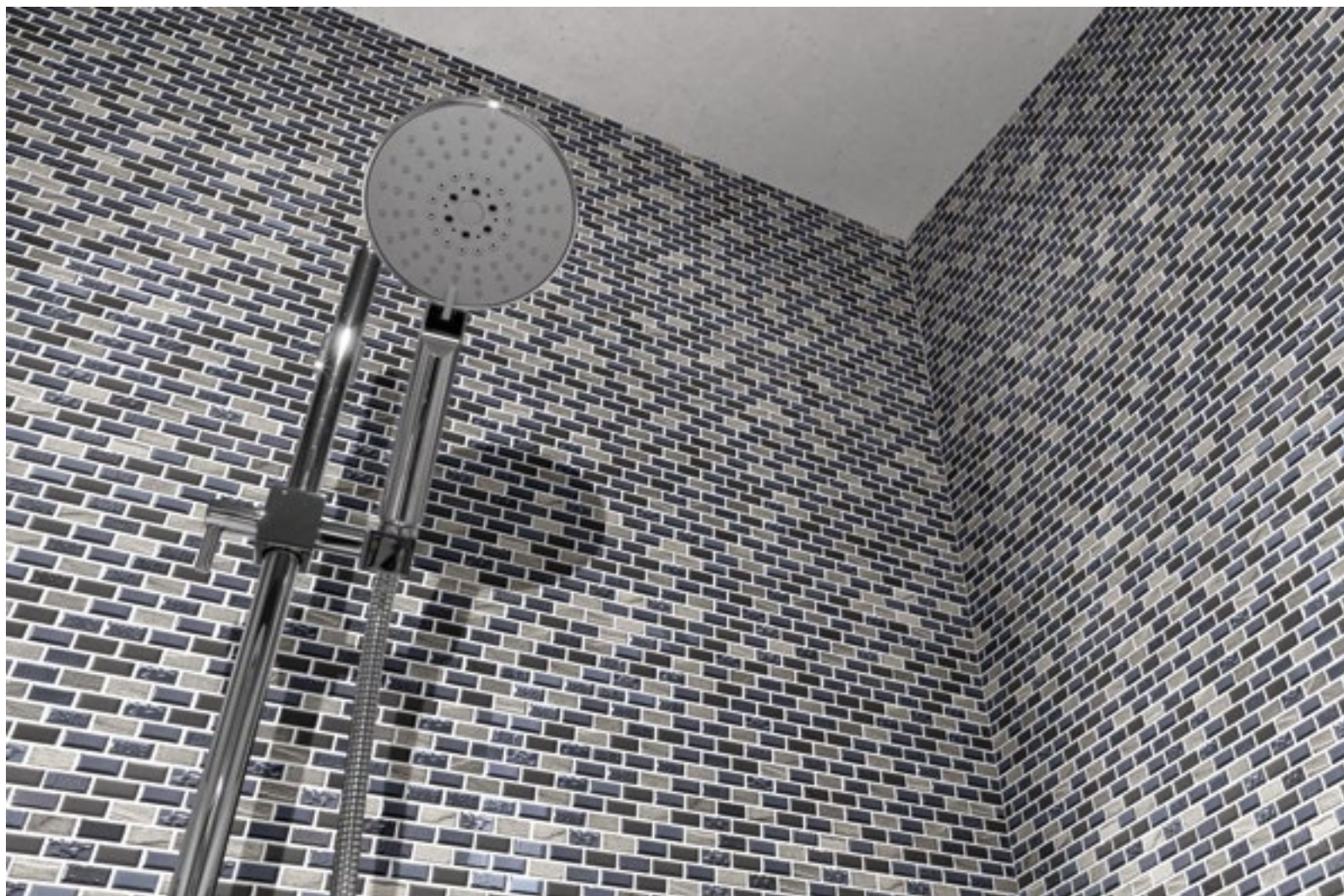

44 Ref. S3340 · FESTO BRICK

MISCELANEA LUX

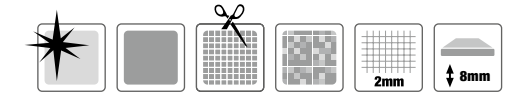

Blends · Composiciones · Combinados

Piece 0,4" x 1" · Pieza 1 x 2,5cm.
Sheet 11,6" x 12" x 0,3" · Panel 29,61 x 30,61 x 0,8 cm.

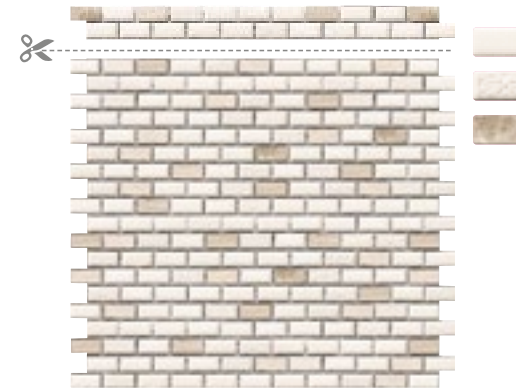

Ref. S3345 ROMAN BRICK | A-39



Ref. S3375 ROMAN RECT | A-39

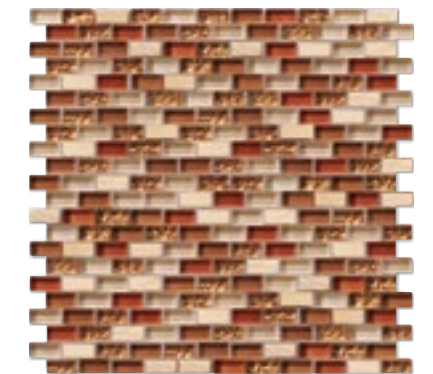

Ref. S3347 OLIMPIA BRICK | A-39

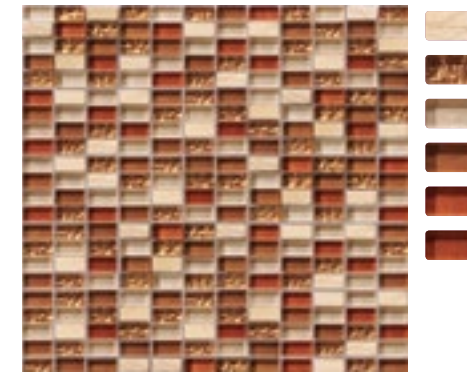

Ref. S3377 OLIMPIA RECT | A-39

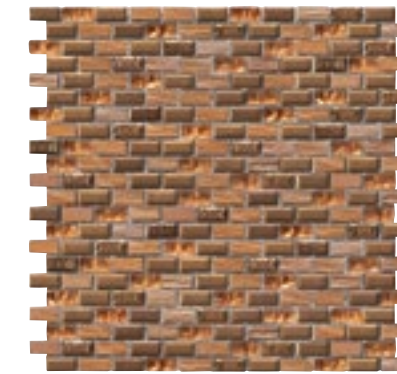

Ref. S3348 BABYLONIA BRICK | A-39

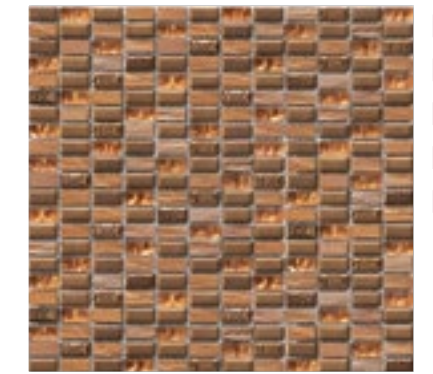

Ref. S3378 BABYLONIA RECT | A-39

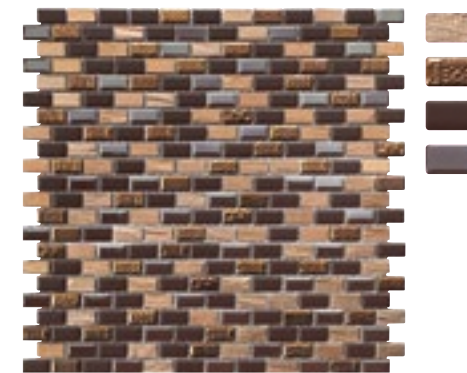

Ref. S3349 ARCADIA BRICK | A-39



Ref. S3370 ARCADIA RECT | A-39



Ref. S3340 FESTO BRICK | A-39



Ref. S3371 FESTO RECT | A-39

PACKING MISCELANEA LUX

SIZE / MESH DIMENSIÓN / HOJA	WEIGHT / BOX PESO / CAJA	M ² / BOX M ² / CAJA	PIECES / BOX PIEZAS / CAJA
29,61 x 30,61 x 0,8 cm. 11,6" x 12" x 0,3"	15,30 kg	1 m ²	11

BOXES / PALLET · EUROPALLET CAJAS / PALET · EUROPALET	M ² / PALLET · EUROPALLET M ² / PALET · EUROPALET	WEIGHT / PALLET · EUROPALLET PESO / PALET · EUROPALET
63 cajas · 42 cajas	63 m ² · 42 m ²	964 kg · 642,30 kg

SIZE / PALLET · MEDIDAS / PALET 105 x 105 x 90 cm.

SIZE / EUROPALLET · MEDIDAS / EUROPALET 120 x 80 x 108 cm.



MUSEUM *collection*



A true work of art. The perfection of the geometry together with the beauty of the metal. An avant-garde art.

Véritables œuvres d'art. La perfection de la géométrie se joint à la beauté du métal. Un art d'avant-garde.

Verdaderas obras de arte. La perfección de la geometría se une a la belleza del metal. Un arte de vanguardia.

SOLID COLORS



Glossy
Brillant
Brillo



Matt
Mat
Mate



Grouts
Joint
Junta



Thickness
Épaisseur
Espesor



Mosaic mesh
Pièce trame
Pieza enmallada



Shade variation
Variation de ton
Destonificación

MULTIPLE FORMATS · MULTIFORMATO



1,2" x 1,2"
3 x 3 cm



0,9" x 0,9"
2,4 x 2,4 cm



1,9" x 0,55"
4,8 x 1,4 cm



1,2" x 0,55"
3 x 1,4 cm



0,55" x 0,55"
1,4 x 1,4 cm

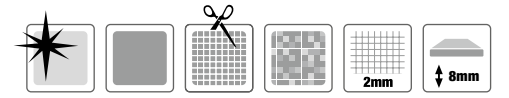

MULTIPLE FORMATS · MULTIFORMATO

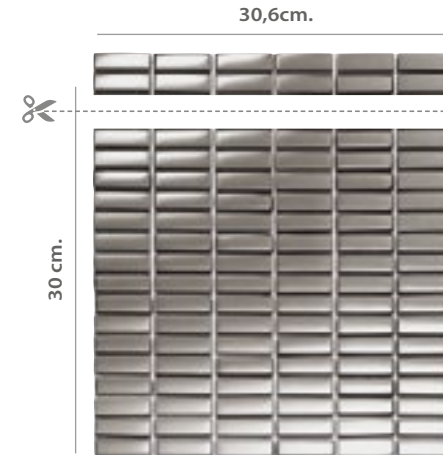

Ref. SB0001 GUGGENHEIM | A-37

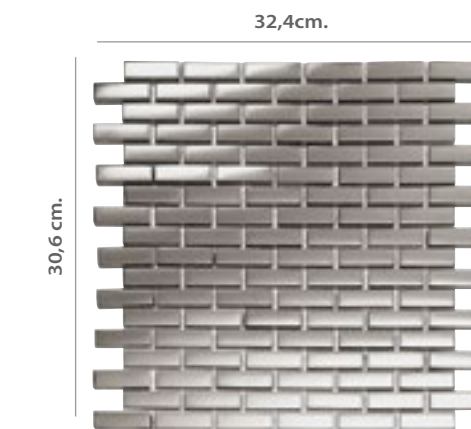

Ref. SB0001B THYSSEN | A-37

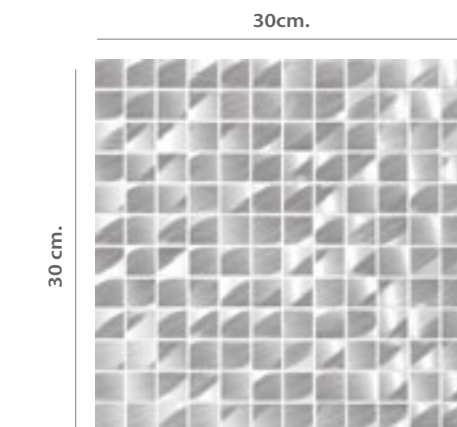

Ref. ME0004 MOMA | A-37

-  **GUGGENHEIM:** Piece 1,9" x 0,55" / Sheet 11,8" x 12" · Pieza 4,8 x 1,4 cm. / Panel 30 x 30,6 cm.
-  **D'ORSAY:** Piece 1,2" x 0,55" / Sheet 11,8" x 11,8" · Pieza 3 x 1,4 cm. / Panel 30 x 30 cm.
-  **POMPIDOU:** Piece 1,2" x 0,55" / Sheet 11,8" x 12" · Pieza 3 x 1,4 cm. / Panel 30 x 30,5 cm.
-  **THYSSEN:** Piece 1,9" x 0,55" / Sheet 12" x 12,7" · Pieza 4,8 x 1,4 cm. / Panel 30,6 x 32,4 cm.
-  **MOMA:** Piece 0,9" x 0,9" / Sheet 11,8" x 11,8" · Pieza 2,4 x 2,4 cm. / Panel 30 x 30 cm.
-  **LOUVRE:** Piece 1,9" x 0,55" / Sheet 11,8" x 11,8" · Pieza 4,8 x 1,4 cm. / Panel 30 x 30 cm.
-  **ROSENTHAL:** Piece 1,2" x 1,2" / Sheet 11,8" x 11,8" · Pieza 3 x 3 cm. / Panel 30 x 30 cm.

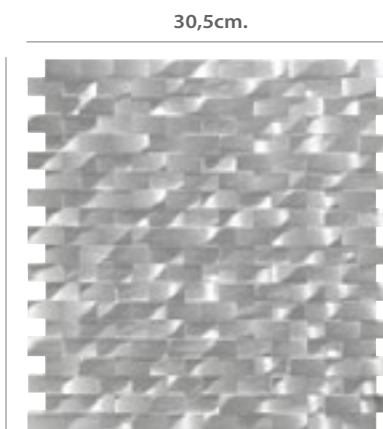

Ref. ME0003 POMPIDOU | A-38

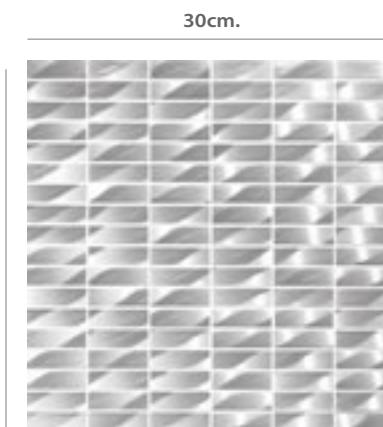

Ref. ME0001 LOUVRE | A-37

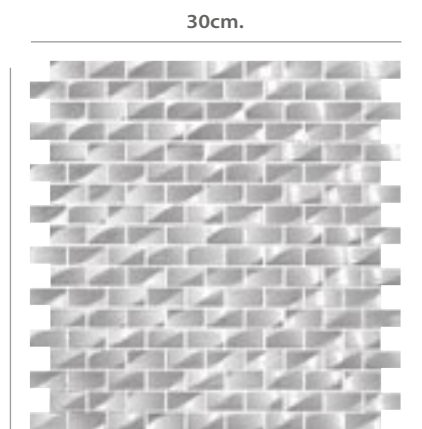

Ref. ME0002 D'ORSAY | A-37

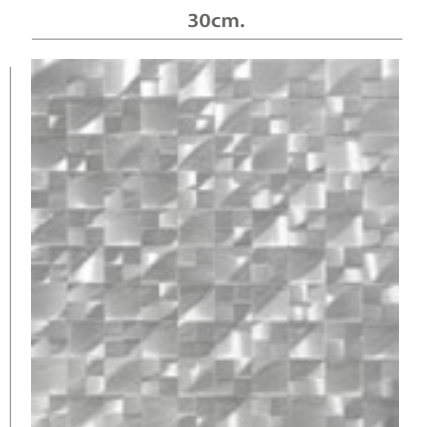

Ref. ME0005 ROSENTHAL | A-38

PACKING MUSEUM

SIZE / MESH DIMENSIÓN / HOJA	WEIGHT / BOX PESO / CAJA	M ² / BOX M ² / CAJA	PIECES / BOX PIEZAS / CAJA	BOXES / PALLET · EUROPAL. CAJAS / PALET · EUROPAL.	M ² / PALLET · EUROPAL. M ² / PALET · EUROPAL.	WEIGHT / PALLET · EUROPAL. PESO / PALET · EUROPAL.
LOUVRE · D'ORSAY 30 x 30 cm. · 11,8" x 11,8"	7,20 kg	0,81 m ²	9	63 cajas · 48 cajas	51,03 m ² · 38,88 m ²	453,6 kg · 345,60 kg
MOMA 30 x 30 cm. · 11,8" x 11,8"	7,19 kg	0,81 m ²	9	63 cajas · 48 cajas	51,03 m ² · 38,88 m ²	453 kg · 345,12 kg
ROSENTHAL 30 x 30 cm. · 11,8" x 11,8"	6,60 kg	0,63 m ²	7	63 cajas · 48 cajas	39,69 m ² · 30,24 m ²	416 kg · 316,80 kg
POMPIDOU 30 x 30,5 cm. · 11,8" x 12"	6,60 kg	0,56 m ²	6	63 cajas · 48 cajas	35,28 m ² · 26,88 m ²	416 kg · 316,80 kg

SIZE / PALLET · MEDIDAS / PALET	105 x 105 x 90 cm.	SIZE / EUROPALLET · MEDIDAS / EUROPALET	120 x 80 x 90 cm.
---------------------------------	--------------------	---	-------------------

GUGGENHEIM 30 x 30,6 cm. · 11,8" x 12"	20,74 kg	1 m ²	11	63 cajas · 42 cajas	63 m ² · 42 m ²	1.306,62 kg · 871,08 kg
THYSSEN 30,6 x 32,4 cm. · 12" x 12,7"	20,74 kg	1 m ²	11	63 cajas · 42 cajas	63 m ² · 42 m ²	1.306,62 kg · 871,08 kg

SIZE / PALLET · MEDIDAS / PALET	105 x 105 x 90 cm.	SIZE / EUROPALLET · MEDIDAS / EUROPALET	120 x 80 x 180 cm.
---------------------------------	--------------------	---	--------------------



ITALY *collection*



Luminous mosaics intermingle capriciously suggesting abstract landscapes.

Lumineux émaux de verre s'entremêlent capricieusement suggérant d'abstraites paysages.

Luminosos mosaicos se entremezclan caprichosamente sugiriendo abstractos paisajes.

SOLID COLORS + BLENDS

- 
 Glossy
Brillant
Brillo
- 
 Grouts
Joint
Junta
- 
 Thickness
Épaisseur
Espesor
- 
 Mosaic mesh
Pièce trame
Pieza enmallada
- 
 Shade variation
Variation de ton
Destonificación

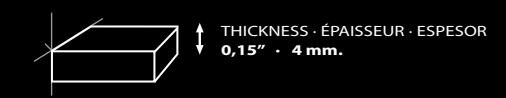
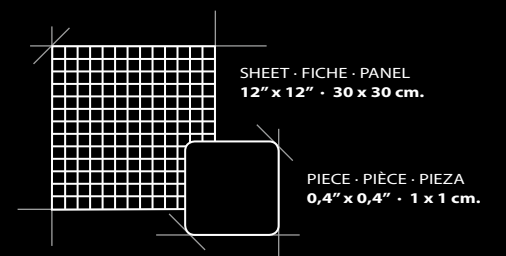

ITALY

Solid colors · Lisses · Lisos

Piece 0,4" x 0,4" · Pieza 1 x 1 cm. Sheet 12" x 12" · Panel 30 x 30 cm.

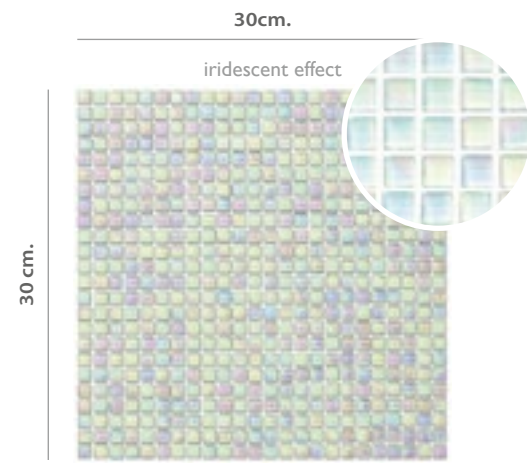
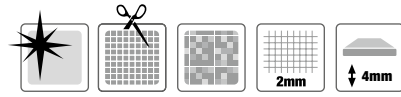

Ref. 1801 VERONA | A-35

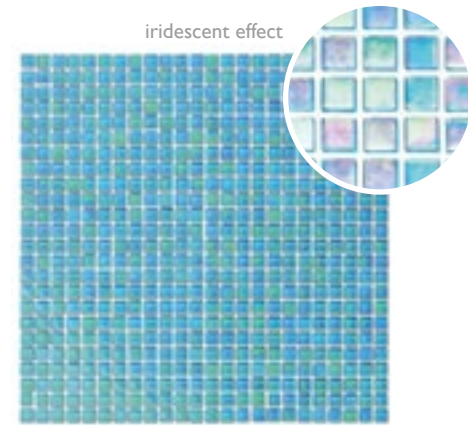

Ref. 1805 FLORENCIA | A-35

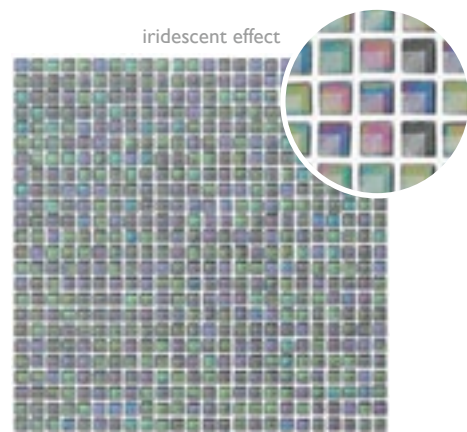

Ref. 1809 ROMA | A-35

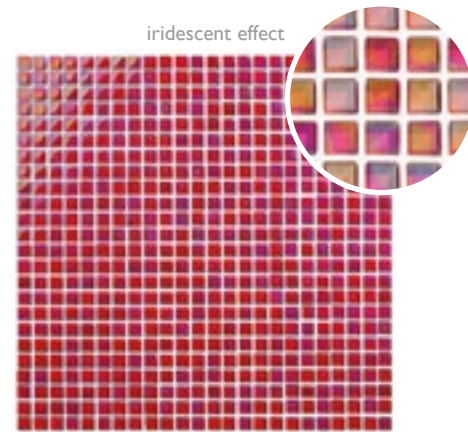

Ref. 1822 VENEZIA | A-36



Ref. 1801 · VERONA

PACKING ITALY

SIZE / MESH DIMENSIÓN / HOJA	WEIGHT / BOX PESO / CAJA	M ² / BOX M ² / CAJA	PIECES / BOX PIEZAS / CAJA
30 x 30 cm. 11,7" x 11,7"	8,50 kg	1 m ²	11

BOXES / PALLET · EUROPALLET CAJAS / PALET · EUROPALET	M ² / PALLET · EUROPALLET M ² / PALET · EUROPALET	WEIGHT / PALLET · EUROPALLET PESO / PALET · EUROPALET
63 cajas · 63 cajas	63 m ² · 63 m ²	535 kg · 535 kg

SIZE / PALLET · MEDIDAS / PALET 105 x 105 x 90 cm.

SIZE / EUROPALLET · MEDIDAS / EUROPALET 120 x 80 x 90 cm.

ITALY

Blends · Composiciones · Combinados

Piece 0,4" x 0,4" · Pieza 1 x 1 cm. Sheet 12" x 12" · Panel 30 x 30 cm.

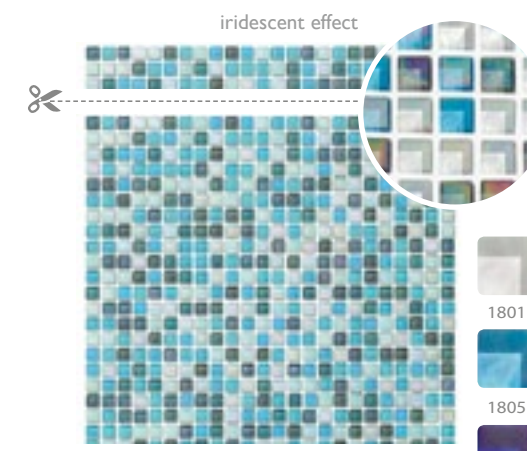

Ref. 1573 ADIGIO | A-36
1801 (33%) + 1805 (33%) + 1809 (33%)

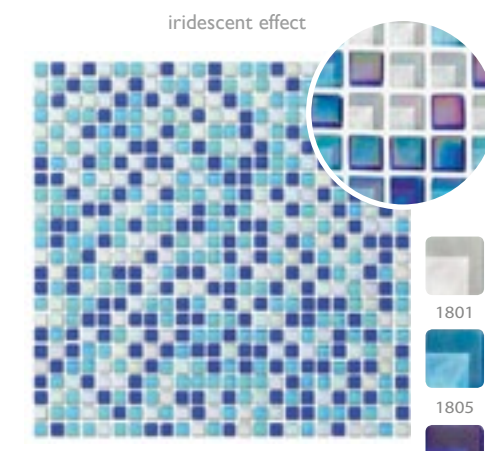

Ref. 1575 TEVERE | A-36
1801 (33%) + 1802 (33%) + 1805 (33%)

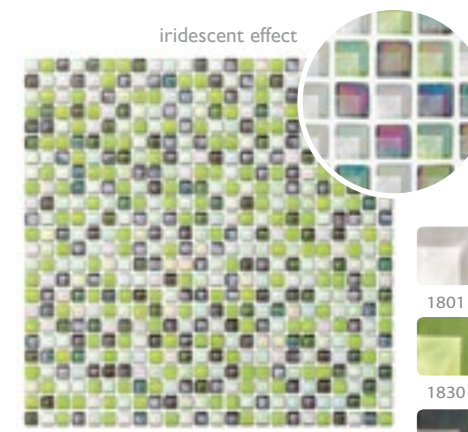

Ref. 1574 ARNO | A-36
1801 (33%) + 1830 (33%) + 1809 (33%)

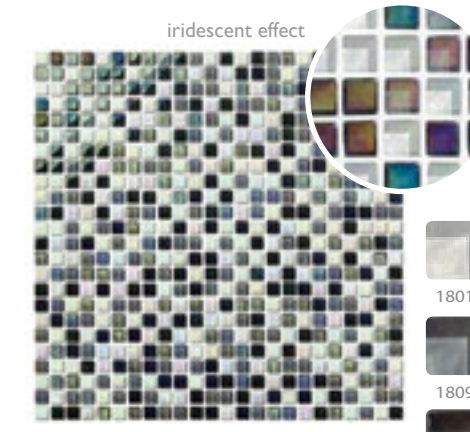

Ref. 1570 RENO | A-36
1801 (33%) + 1809 (33%) + 1810 (33%)

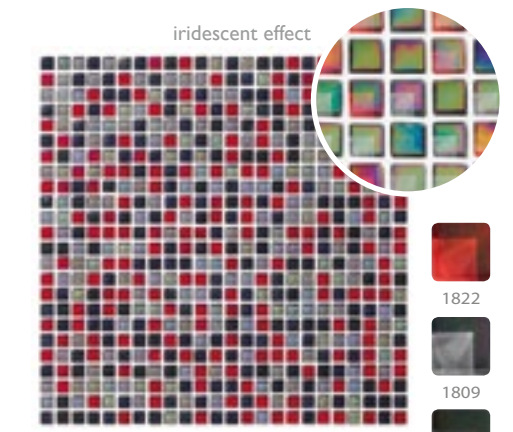

Ref. 1572 TESINO | A-36
1822 (33%) + 1809 (33%) + 1810 (33%)



Ref. 1574 · BLEND ARNO / COMBINADO ARNO

PRECIOUS STONES *collection*



All the reflections of the rainbow made in mosaic. Big iridescent sparkles who will fill up every room of color.

Tous les reflets de l'arc en ciel en mosaïque. De grands éclats irisés qui inondera de couleurs chaque recoin.

Todo el reflejo del arco iris hecho mosaico. Grandes destellos iridiscentes que inundarán de color cada rincón.

BLENDS



Glossy
Brillant
Brillo



Grouts
Joint
Junta



Thickness
Épaisseur
Espesor

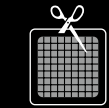

Mosaic mesh
Pièce trame
Pieza enmallada



Shade variation
Variation de ton
Destonificación

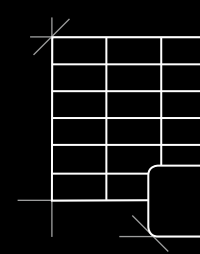

SHEET · FICHE · PANEL
11,8" x 12,1" · 30 x 30,8 cm.

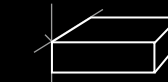

PIECE · PIÈCE · PIEZA
3,9" x 1,9" · 9,8 x 4,8 cm.

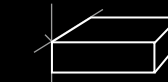

THICKNESS · ÉPAISSEUR · ESPESOR
0,3" · 8 mm.

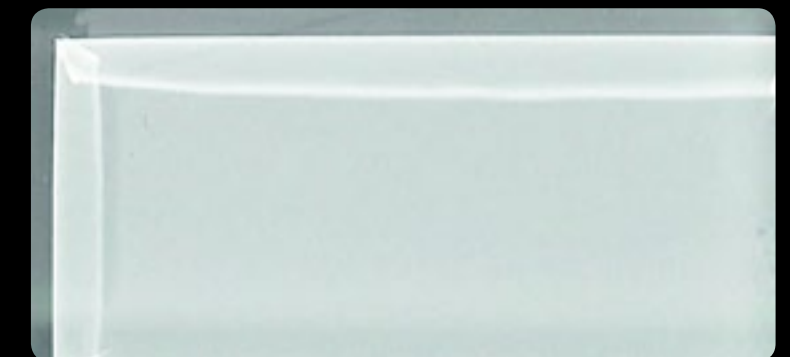

PRECIOUS STONES



PRECIOUS STONE



Blends · Composiciones · Combinados

Piece 1,9" x 3,8" · Pieza 4,8 x 9,8 cm. Sheet 11,8" x 12,1" x 0,3" · Panel 30 x 30,8 x 0,8 cm.

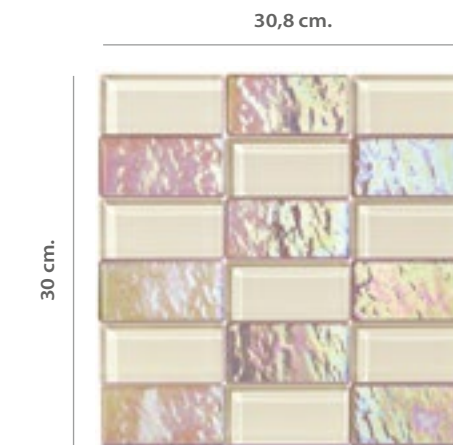

Ref. S4003 QUARTZ | A-35

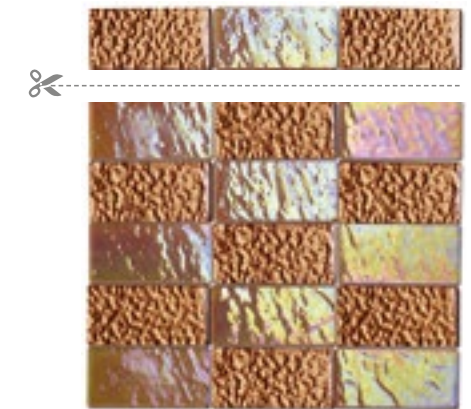

Ref. S4007 AMBER | A-35



Ref. S4001 DIAMOND | A-35

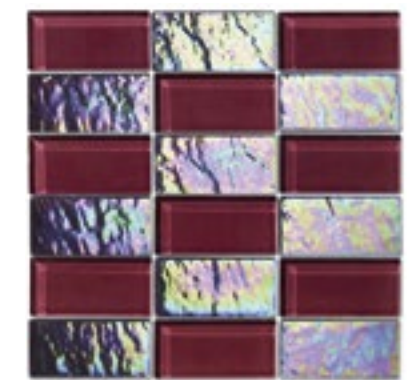

Ref. S4004 RUBI | A-35

PACKING PRECIOUS STONES

SIZE / MESH DIMENSIÓN / HOJA	WEIGHT / BOX PESO / CAJA	M ² / BOX M ² / CAJA	PIECES / BOX PIEZAS / CAJA
30 x 30,8 x 0,8 cm. 11,8" x 12,1" x 0,3	17,50 kg	1 m ²	11

BOXES / PALLET · EUROPALET CAJAS / PALET · EUROPALET	M ² / PALLET · EUROPALET M ² / PALET · EUROPALET	WEIGHT / PALLET · EUROPALET PESO / PALET · EUROPALET
63 cajas · 42 cajas	63 m ² · 42 m ²	1.102,5 kg · 735 kg

SIZE / PALLET · MEDIDAS / PALET 105 x 105 x 90 cm.

SIZE / EUROPALET · MEDIDAS / EUROPALET 120 x 80 x 101 cm.

ALPS *collection*



A combination between shines and mattes, glass and stone. A full set of formats perfectly coordinated to create exclusives environments.

Combinaison entre brillance et mat, de verre et de Pierre. Tout un jeu de formats parfaitement harmonisés pour créer des environnements exclusifs.

Combinación entre brillos y mates, vidrio y piedra. Todo un juego de formatos perfectamente armonizado para crear ambientes exclusivos.

BLENDS



Glossy
Brillant
Brillo



Grouts
Joint
Junta



Thickness
Épaisseur
Espesor



Mosaic mesh
Pièce trame
Pieza enmallada



Shade variation
Variation de ton
Destonificación

MULTIPLE FORMATS · MULTIFORMATO



3,7" x 1,8"
9,5 x 4,5 cm



1,8" x 1,8"
4,5 x 4,5 cm



1,8" x 0,9"
4,5 x 2,2 cm



0,9" x 0,9"
2,2 x 2,2 cm

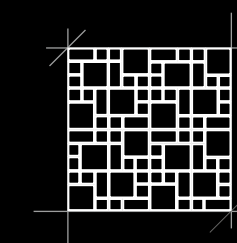

SHEET · FICHE · PANEL
11,8" x 12,1" · 30 x 30,8 cm.

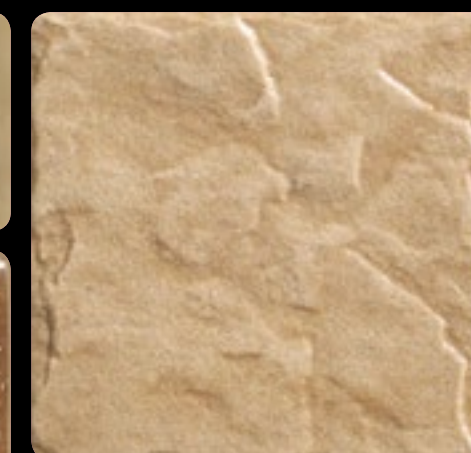

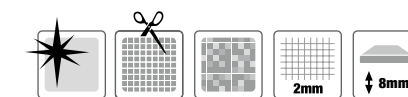

Ref. S0001 BERNA | A-35



Ref. S0002 CERVINO | A-35

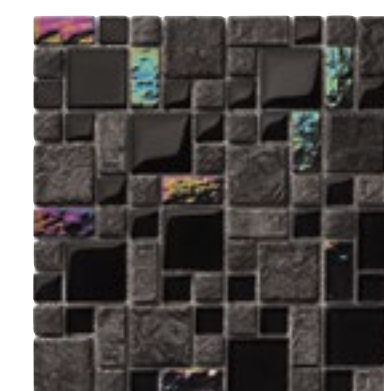

Ref. S0003 TIROL | A-35

PACKING

SIZE / MESH DIMENSION / HOJA	WEIGHT / BOX PESO / CAJA	M ² / BOX M ² / CAJA	PIECES / BOX PIEZAS / CAJA
30 x 30,8 x 0,8 cm. 11,8" x 12,1" x 0,3	18,73 kg	1 m ²	11

BOXES / PALLET · EUROPALET CAJAS / PALET · EUROPALET	M ² / PALLET · EUROPALET M ² / PALET · EUROPALET	WEIGHT / PALLET · EUROPALET PESO / PALET · EUROPALET
63 cajas · 42 cajas	63 m ² · 42 m ²	1.180 kg · 786,66 kg

SIZE / PALLET · MEDIDAS / PALET 105 x 105 x 90 cm.

SIZE / EUROPALET · MEDIDAS / EUROPALET 120 x 80 x 101 cm.

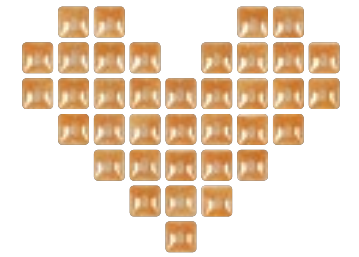

TECHNICAL DETAILS

SECTION TECHNIQUE · ÁREA TÉCNICA

Technical Data Caractéristique Technique Características Técnicas	Norm Norme Norma	ALTOGLASS Standards Valeur ALTOGLASS Valor ALTOGLASS
Water Absorption Absortion d'eau Absorción de Agua	UNE-EN-ISO 10545-3	0 %
Scratch Hardness Résistance aux Rayures Dureza al Rayado (MOHS)	EN 101	3 - 4
Chemical Resistance Résistance Chimique Resistencia Química	UNE-EN-ISO 10545-13	GA / GHA / GLA
Frost Resistance Résistance au Gel Resistencia a la Helada	UNE-EN-ISO 10545-12	OK
Stain Resistance Résistance aux Taches Resistencia a las Manchas	UNE-EN-ISO 10545-14	CLASS 5 CLASSE 5 CLASE 5
Nonslip Treatment Technical Data Caractéristique Technique Traitement Antiderapant Características Tratamiento Antideslizante	Norm Norme Norma	ALTOGLASS Standards Valeur ALTOGLASS Valor ALTOGLASS
Tortus Method "Dinamic Slider" Methode Tortus "Dérapant Dynamique" Método Tortus "Deslizamiento Dinámico"	ISO / DIS 10545-17	CLASS 2 CLASSE 2 CLASE 2 $fh \geq 0,4$
Slip Resistance Résistance a L'antiderapant Resistencia al Deslizamiento	DIN 51097  $\alpha = 33^\circ$	CLASS A+B+C CLASSE A+B+C $(\alpha > 33)$ CLASE A+B+C
Method USRV without Polishing. Friction Pendulum USRV Méthode sans Polissage. Pendule de Frottement Método USRV sin Pulir. Péndulo de Fricción	UNE-ENV 12633:2003	CLASS 3 CLASSE 3 CLASE 3

FITTING ADVISE

CONSEJOS DE COLOCACIÓN · CONSEILS DE POSE



1

Spread a coat of adhesive-based cement across the surface, ensuring that it is flat and even.

Appliquer uniformément le mortier colle sur la surface totalement à niveau.

Aplicar uniformemente el cemento cola sobre la superficie bien nivelada.



2

Place the mesh-mounted mosaics on top of the cement and press them down with a rubber trowel to guarantee an even surface.

Pose le filet de mosaïque sur le mortier et comprimer à l'aide d'une taloche en caoutchouc en veillant à égaliser les pièces.

Colocar la malla de mosaico sobre el cemento y ejercer presión con una llana de goma para igualar las piezas.



3

Leveling all the pieces

Aplanir toutes les pièces.

Nivelar todas las piezas.

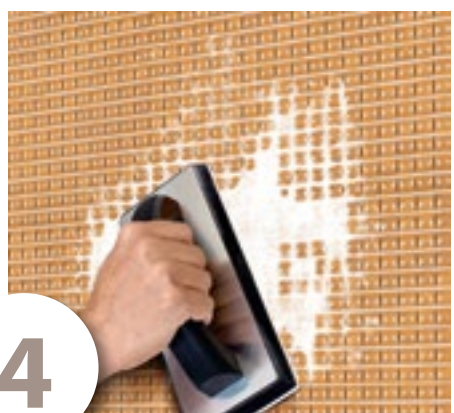

4

Once it is dry, it can be grouted.

Après séchage, procéder à rejointer.

Una vez esté seco procederemos a aplicar el material de rejunte.



5

Lastly, clean the surface with a damp sponge and then with a dry cloth.

Enfin, nettoyer la surface à l'aide d'une éponge humide, puis passer un linge sec.

Por último, limpiaremos la superficie con una esponja húmeda y posteriormente con un trapo seco.

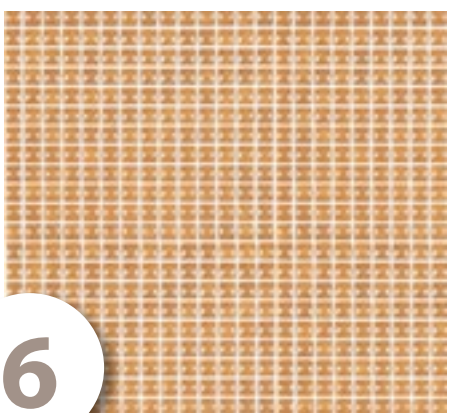

6

Final result.

Resultat final.

Acabado final.

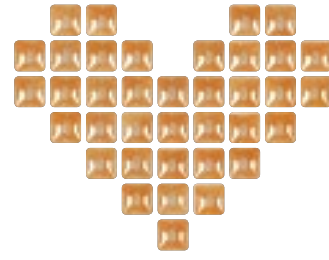

PACKING LIST

COLLECTION COLECCIÓN	SIZE / MESH DIMENSIÓN / HOJA	WEIGHT / BOX PESO / CAJA	SQM / BOX M ² / CAJA	PIECES / BOX PIEZAS / CAJA	BOXES / PALLET · EUROPAL. CAJA / PALET · EUROPALET.	SQM / PALLET · EUROPAL. M ² / PALET · EUROPALET.	WEIGHT / PALLET · EUROPAL. PESO / PALET · EUROPALET.
TISSUE							
TUL	30 x 30 cm. 11,8" x 11,8"	7 kg	0,99 m ²	11	72 cajas · 42 cajas	71,20 m ² · 41,53 m ²	504 kg · 294 kg
BROCADO	30 x 30 cm. 11,8" x 11,8"	6,98 kg	0,63 m ²	7	72 cajas · 42 cajas	45,37 m ² · 26,47 m ²	502,86 kg · 293,33 kg
TAFETTAN	29 x 30 cm. 11,4" x 11,8"	6,98 kg	0,61 m ²	7	72 cajas · 42 cajas	43,89 m ² · 25,60 m ²	502,86 kg · 293,33 kg
SEDA OFF	31,2 x 33,8 cm. 12,3" x 13,3"	12,79 kg	1,16 m ²	11	72 cajas · 42 cajas	83,44 m ² · 48,67 m ²	921,18 kg · 537,35 kg
SEDA SHINE	31,2 x 33,8 cm. 12,3" x 13,3"	11,76 kg	1,16 m ²	11	72 cajas · 42 cajas	83,44 m ² · 48,67 m ²	847,06 kg · 494,12 kg
ORGANZA	31,2 x 33,8 cm. 12,3" x 13,3"	11,76 kg	1,16 m ²	11	72 cajas · 42 cajas	83,44 m ² · 48,67 m ²	847,06 kg · 494,12 kg
GAZAN	32,4 x 30 cm. 12,7" x 11,8"	11,76 kg	1,07 m ²	11	72 cajas · 42 cajas	77,08 m ² · 44,96 m ²	847,06 kg · 494,12 kg
RASO	32,4 x 30 cm. 12,7" x 11,8"	11,76 kg	1,07 m ²	11	72 cajas · 42 cajas	77,08 m ² · 44,96 m ²	847,06 kg · 494,12 kg
DENIM	32,4 x 30 cm. 12,7" x 11,8"	11,76 kg	1,07 m ²	11	72 cajas · 42 cajas	77,08 m ² · 44,96 m ²	847,06 kg · 494,12 kg
MUSELINA	32,4 x 30 cm. 12,7" x 11,8"	11,76 kg	1,07 m ²	11	72 cajas · 42 cajas	77,08 m ² · 44,96 m ²	847,06 kg · 494,12 kg
SATEN	32,4 x 30 cm. 12,7" x 11,8"	11,76 kg	1,07 m ²	11	72 cajas · 42 cajas	77,08 m ² · 44,96 m ²	847,06 kg · 494,12 kg
CHANTILLI	32,4 x 30 cm. 12,7" x 11,8"	11,76 kg	1,07 m ²	11	72 cajas · 42 cajas	77,08 m ² · 44,96 m ²	847,06 kg · 494,12 kg
COOL	30 x 30 cm. 11,8" x 11,8"	16 kg	1 m ²	11	72 cajas · 42 cajas	72 m ² · 42 m ²	1.152 kg · 672 kg
ITALY	30 x 30 cm. 11,8" x 11,8"	8,50 kg	1 m ²	11	63 cajas	63 m ²	535 kg
MUSEUM							
LOUVRE	30 x 30 cm. 11,8" x 11,8"	7,2 kg	0,81 m ²	9	63 cajas · 48 cajas	51,03 m ² · 38,88 m ²	453,6 kg · 345,60 kg
D'ORSAY	30 x 30 cm. 11,8" x 11,8"	7,2 kg	0,81 m ²	9	63 cajas · 48 cajas	51,03 m ² · 38,88 m ²	453,6 kg · 345,60 kg
MOMA	30 x 30 cm. 11,8" x 11,8"	7,19 kg	0,81 m ²	9	63 cajas · 48 cajas	51,03 m ² · 38,88 m ²	453 kg · 345,12 kg
ROSENTHAL	30 x 30 cm. 11,8" x 11,8"	6,60 kg	0,63 m ²	7	63 cajas · 48 cajas	39,69 m ² · 30,24 m ²	416 kg · 316,80 kg
POMPIDOU	30 x 30,5 cm. 11,8" x 12"	6,60 kg	0,56 m ²	6	63 cajas · 48 cajas	35,28 m ² · 26,88 m ²	416 kg · 316,80 kg
SIZE / PALLET · MEDIDAS / PALET 105 x 105 x 90 cm.				SIZE / EUROPALET · MEDIDAS / EUROPALET 120 x 80 x 90 cm.			
MUSEUM							
GUGGENHEIM	30 x 30,6 cm. 11,8" x 12"	20,74 kg	1 m ²	11	63 cajas · 42 cajas	63 m ² · 42 m ²	1306,62 kg · 871,08 kg
THYSSEN	30,6 x 32,4 cm. 12" x 12,7"	20,74 kg	1 m ²	11	63 cajas · 42 cajas	63 m ² · 42 m ²	1306,62 kg · 871,08 kg
VOLCANO	30,1 x 30,1 x 0,8 cm. 11,7" x 11,7" x 0,3	14 kg	1 m ²	11	63 cajas · 42 cajas	63 m ² · 42 m ²	882 kg · 588 kg
MISCELANEA	30,1 x 30,1 x 0,8 cm. 11,7" x 11,7" x 0,3	15,30 kg	1 m ²	11	63 cajas · 42 cajas	63 m ² · 42 m ²	964 kg · 642,30 kg
MISCELANEA LUX	29,61 x 30,61 x 0,8 cm. 11,6" x 12" x 0,3	15,30 kg	1 m ²	11	63 cajas · 42 cajas	63 m ² · 42 m ²	964 kg · 642,30 kg
SIZE / PALLET · MEDIDAS / PALET 105 x 105 x 90 cm.				SIZE / EUROPALET · MEDIDAS / EUROPALET 120 x 80 x 108 cm.			
PRECIOUS STONES	30 x 30,8 x 0,8 cm. 11,8" x 12,1" x 0,3	17,5 kg	1 m ²	11	63 cajas · 42 cajas	63 m ² · 42 m ²	1102,5 kg · 735 kg
ALPS	30 x 30,8 x 0,8 cm. 11,8" x 12,1" x 0,3	18,73 kg	1 m ²	11	63 cajas · 42 cajas	63 m ² · 42 m ²	1180 kg · 786,66 kg
SIZE / PALLET · MEDIDAS / PALET 105 x 105 x 90 cm.				SIZE / EUROPALET · MEDIDAS / EUROPALET 120 x 80 x 101 cm.			